

martin®

Martin® ***Self Adjusting Skirting***

[Go to Martin® Self Adjusting Skirting web page](#)



Operator's Manual
M3612

Important

MARTIN ENGINEERING HEREBY DISCLAIMS ANY LIABILITY FOR: DAMAGE DUE TO CONTAMINATION OF THE MATERIAL; USER'S FAILURE TO INSPECT, MAINTAIN AND TAKE REASONABLE CARE OF THE EQUIPMENT; INJURIES OR DAMAGE RESULTING FROM USE OR APPLICATION OF THIS PRODUCT CONTRARY TO INSTRUCTIONS AND SPECIFICATIONS CONTAINED HEREIN. MARTIN ENGINEERING'S LIABILITY SHALL BE LIMITED TO REPAIR OR REPLACEMENT OF EQUIPMENT SHOWN TO BE DEFECTIVE.

Observe all safety rules given herein along with owner and Government standards and regulations. Know and understand lockout/tagout procedures as defined by American National Standards Institute (ANSI) z244.1-1982, *American National Standard for Personnel Protection - Lockout/Tagout of Energy Sources - Minimum Safety Requirements* and Occupational Safety and Health Administration (OSHA) Federal Register, Part IV, 29 CFR Part 1910, *Control of Hazardous Energy Source (Lockout/Tagout); Final Rule*.

The following symbols may be used in this manual:



Danger: Immediate hazards that will result in severe personal injury or death.



Warning: Hazards or unsafe practices that could result in personal injury.



Caution: Hazards or unsafe practices that could result in product or property damages.



Important: Instructions that must be followed to ensure proper installation/operation of equipment.



Note: General statements to assist the reader.

Table of Contents

Section	Page
List of Figures/Tables	ii
Introduction	1
General	1
References	1
Safety	1
Materials Required	1
Before Installing Skirting	2
Installing Skirting	4
After Installing Skirting	13
Maintenance	14
Part Numbers	15
Appendix. Martin® Self Adjusting Interior Skirting Installation	A-1

List of Figures

Figure	Title	Page
1	Minimum Space Required for Installation	4
2	Locating Chute Wall and Wear Liner	4
3a	Placing Back Plate Weldments onto Belt	5
3b	Placing Back Plate Weldments onto Belt	5
3c	Placing Back Plate Weldments onto Belt	6
3d	Placing Back Plate Weldments onto Belt	7
4a	Placing Back Plate Weldments onto Belt	7
4b	Placing Back Plate Weldments onto Belt	8
4c	Placing Back Plate Weldments onto Belt	8
5	Welding into Place	9
6	Placement of Rubber Skirt	9
7a	Placing Rubber Skirting over Pins	10
7b	Placing Rubber Skirting over Pins	10
7c	Placing Rubber Skirting over Pins	11
8	Lining Up Holes in Pressure Arms.	11
9	Martin [®] Self Adjusting Skirting Assembly, P/N 37911-XX	16
10	Martin [®] Self Adjusting Skirting Assembly, P/N 37911-SS.	18
11	Conveyor Products Warning Label, P/N 23395	19
12	Belt Direction Label Placement	19

List of Tables

Table	Title	Page
I	Material Specifications.	1
II	Part Numbers for Martin [®] Self Adjusting Skirting Assembly, P/N 37911-XX.	17

Introduction

General

Martin® Self Adjusting Skirting is a self-adjusting conveyor belt skirting system that prevents spillage without requiring regular service to maintain an effective seal. Martin® Self Adjusting Skirting is covered under patent 6,575,294.

References

The following documents are referenced in this manual:

- American National Standards Institute (ANSI) z244.1-1982, *American National Standard for Personnel Protection - Lockout/Tagout of Energy Sources - Minimum Safety Requirements*, American National Standards Institute, Inc., 1430 Broadway, New York, NY 10018.
- Federal Register, Volume 54, Number 169, Part IV, 29 CFR Part 1910, *Control of Hazardous Energy Source (Lockout/Tagout); Final Rule*, Department of Labor, Occupational Safety and Health Administration (OSHA), 32nd Floor, Room 3244, 230 South Dearborn Street, Chicago, IL 60604.

Safety

All safety rules defined in the above documents and all owner/employer safety rules must be strictly followed when working on this equipment.

Material required

Standard hand tools, welder, torch and knife are required to install this equipment.

Table I. Material Specifications

Type	Material	Durometer	Service Temperature Range
Rubber Seal	EPDM	70 Shore A	-20 to 250°F -29 to 71°C

Before Installing Skirting

IMPORTANT

The delivery service is responsible for damage occurring in transit. Martin Engineering CANNOT enter claims for damages. Contact your transportation agent for more information.

1. Inspect shipping container for damage. Report damage to delivery service immediately and fill out delivery service's claim form. Keep any damaged goods subject to examination.
2. Remove skirting system from shipping container. Equipment in container should include the following:
 - Martin® Self Adjusting Skirting.
 - Two Conveyor Products Warning Labels, P/N 23395.
3. If anything is missing, contact Martin Engineering or a representative.
4. The rubber seal may be shipped separately depending upon how it was ordered.



WARNING

Before installing equipment, lock out/tag out energy source to conveyor and conveyor accessories.

5. Turn off and lock out/tag out energy source according to ANSI standards (see "References").

WARNING

If equipment will be installed in an enclosed area, test gas level or dust content before using a cutting torch or welding. Using a cutting torch or welding in an area with gas or dust may cause an explosion.

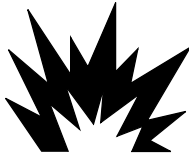

6. If using a cutting torch or welding, test atmosphere for gas level or dust content.
7. Cover conveyor belt with fire retardant cover and have fire extinguisher available.

NOTE

Contact Martin Engineering before installing reversing belt applications, or where a floating seal is insufficient sealing pressure.

IMPORTANT

Martin® Self Adjusting Skirting, like all skirting systems, is susceptible to belt mistracking. Observe the tracking of the belt in the load zone and if the belt mistracks to the extent that the belt will travel out from under the Martin® Self Adjusting Skirting install a Martin® Tracker™ to maintain proper alignment. Failure to keep the belt properly tracked may result in premature failure of the skirt rubber, damage to the belt or conveyor system, and unnecessary spillage.

Installing Skirting

IMPORTANT

Read entire section before beginning work.

For installation of Martin® Self Adjusting Interior Skirting refer to the Appendix.

For maximum skirting effectiveness, Martin Engineering recommends using Martin® Wear Liners with Martin® Self Adjusting Skirting (see “Part Numbers” for ordering information). Make sure chute wall and wear liners are straight and well-supported.

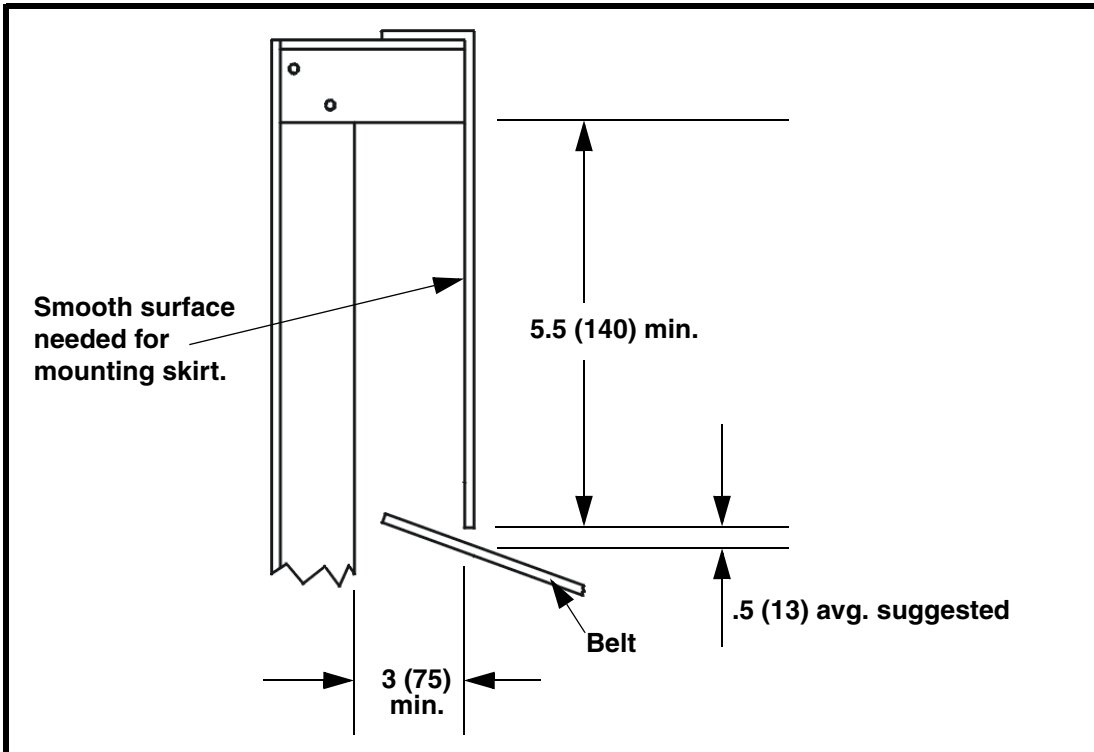

Figure 1. Minimum Space Required for Installation

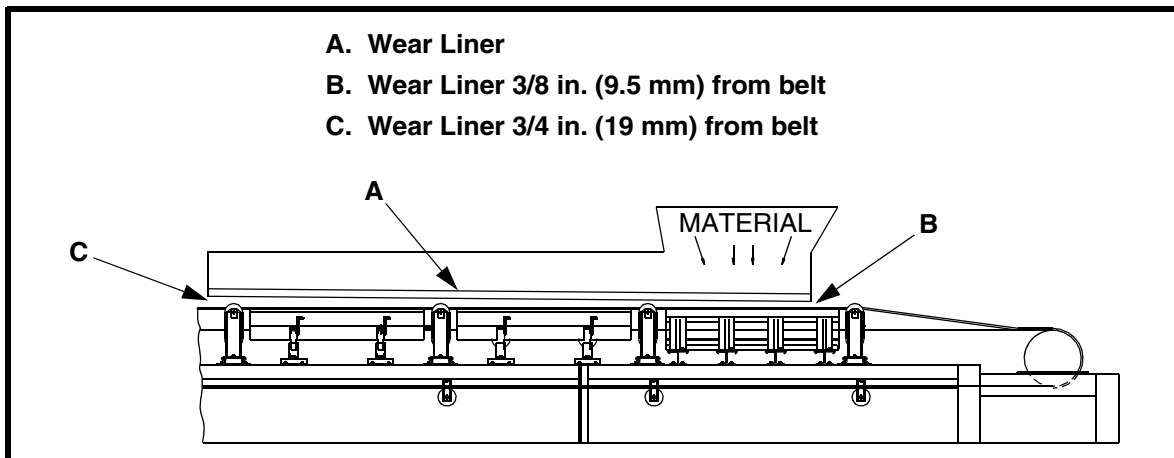

Figure 2. Locating Chute Wall and Wear Liner

1. Remove existing skirting.
2. Ensure that surface of chute is flat and free of anything that will hinder welding.
3. Start installation on upstream end of chute work.

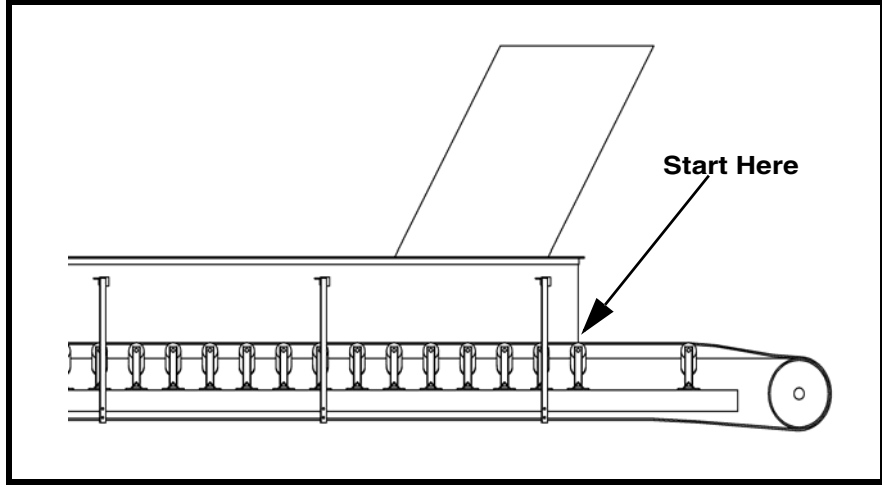

Figure 3a. Placing Back Plate Weldments onto Belt

4. Place one installation tool (P/N 37918) on belt above the first idler.

NOTE

Use tab on end of installation tool to “hook” over belt edge for stability.

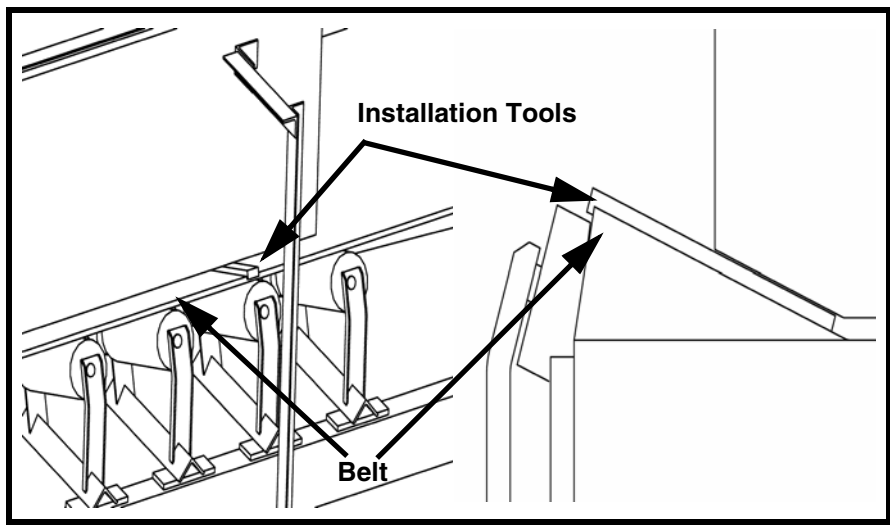

Figure 3b. Placing Back Plate Weldments onto Belt

5. Place the next installation tool on belt above an idler approximately 36 inches (914 mm) downstream from first tool.

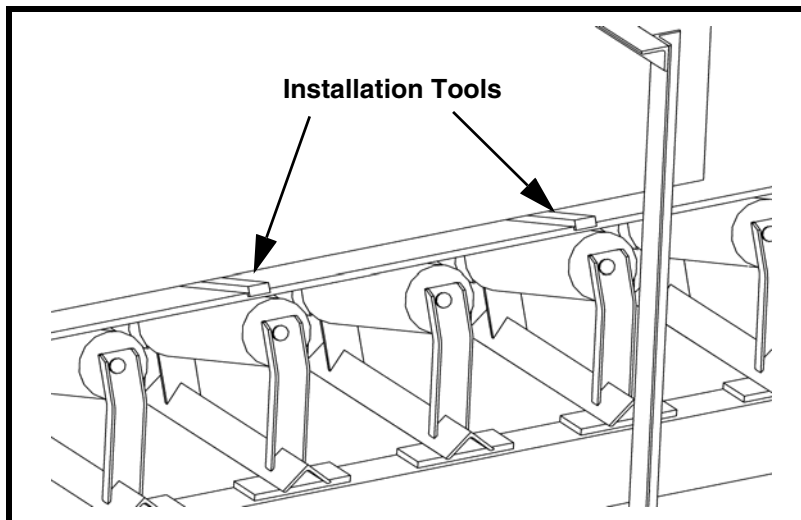

Figure 3c. Placing Back Plate Weldments onto Belt

NOTE

The 1/2-inch (13-mm) spacer insures skirting has room to float, and that no steel from floating skirt or links can touch belt.

NOTE

If the chute wall is rough or there are wear liner bolts present, install a spacer which provides enough room for access to the wear liner bolts and provides a smooth surface for the skirting to float against.

- 6. Place the Martin® Self Adjusting Skirting plate (P/N 37912) onto chute and resting on installation tools. Ensure that back plate extends beyond the end of chute by 6 inches (152 mm).

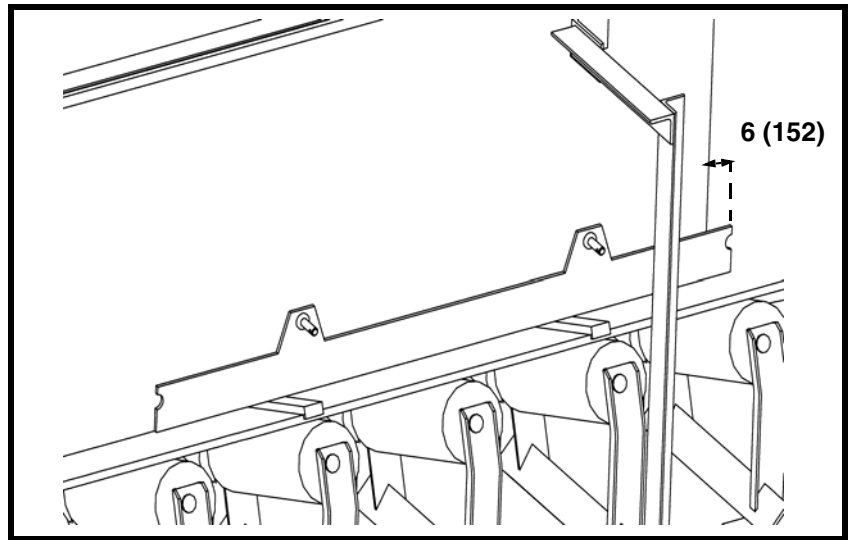

Figure 3d. Placing Back Plate Weldments onto Belt

- 7. Tack weld the back plate to chute wall
- 8. Place installation tools on belt, above idlers, downstream of the welded back plate.

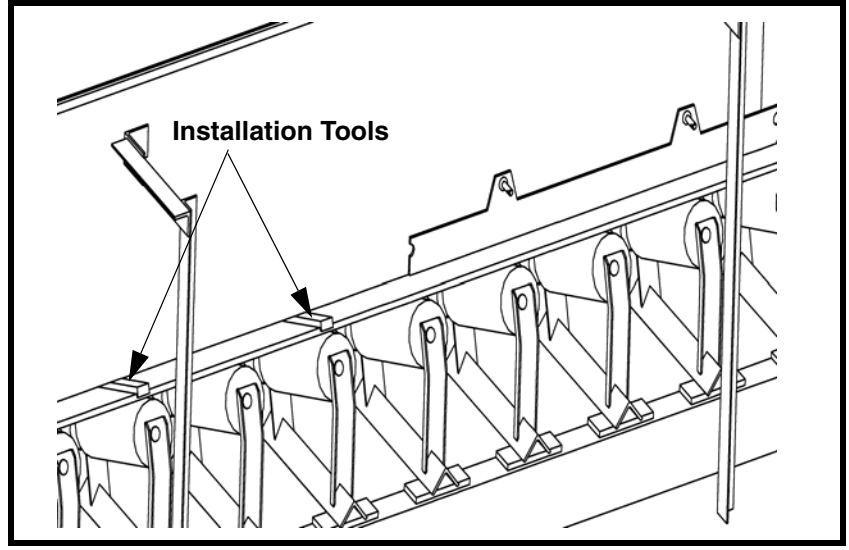

Figure 4a. Placing Back Plate Weldments onto Belt

9. Place the Martin[®] Self Adjusting Skirting back plate (P/N 37912) onto chute and resting on installation tools. Ensure that the loose back plate is flush up against welded back plate.

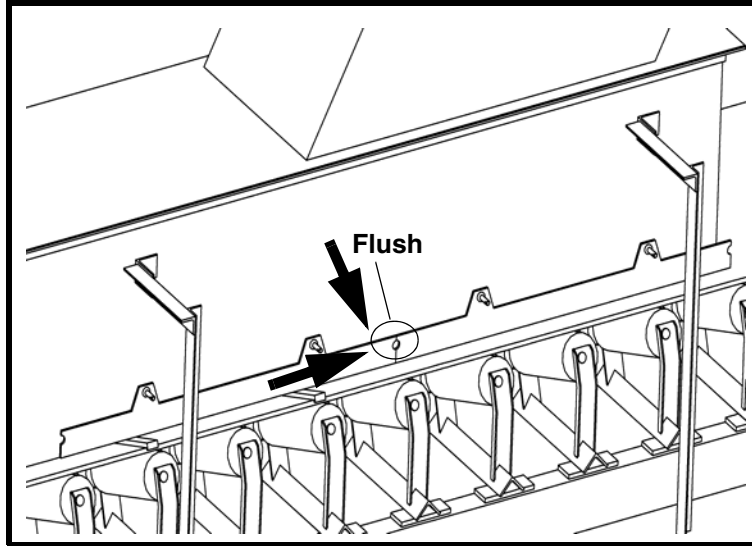

Figure 4b. Placing Back Plate Weldments onto Belt

10. Repeat steps 8 and 9 until entire length of chute is covered with back plates.

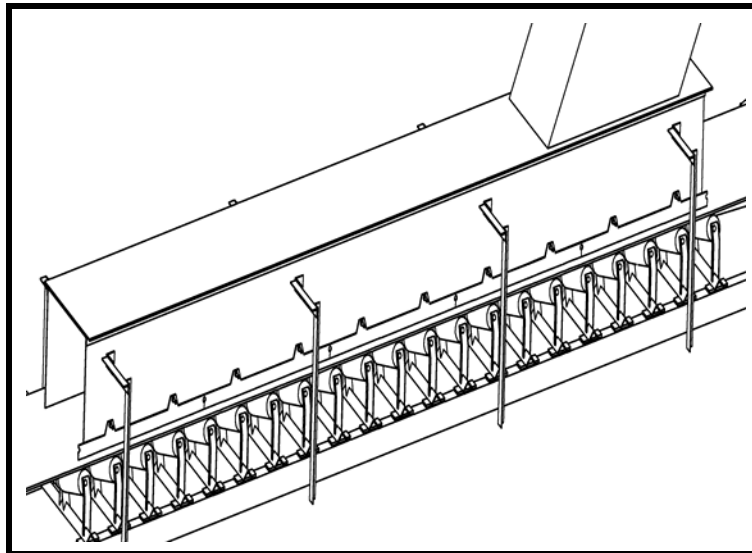

Figure 4c. Placing Back Plate Weldments onto Belt

11. Securely weld all back plates to chute wall.

NOTE

Ensure that weld does not extend beyond surface of back plate.

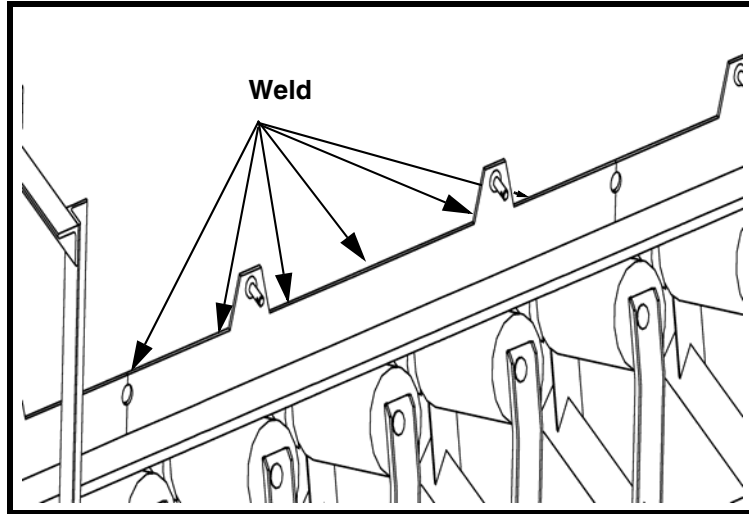

Figure 5. Welding into Place

12. Repeat steps 3–11 on other side of the chute work.

13. Place the rubber (P/N 37911-R) on belt as shown with indentation toward chute wall.

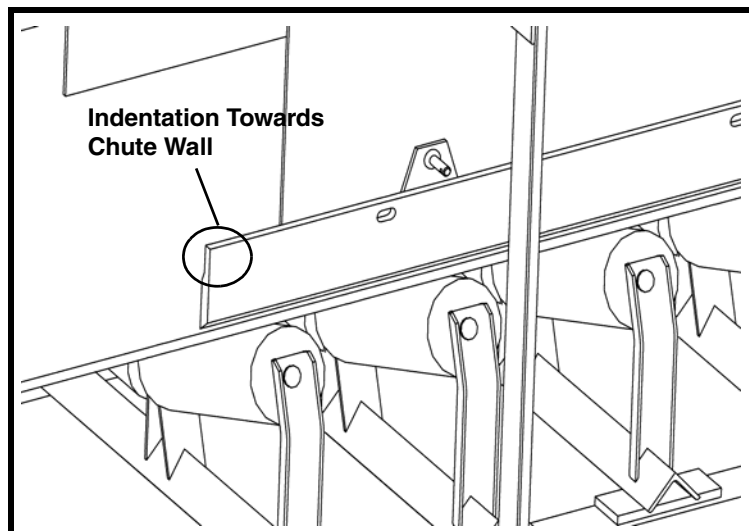

Figure 6. Placement of Rubber Skirt

14. Place mount weldments (P/N 37915) on chute side of rubber with the studs going through the holes in rubber. Place clamp plates (P/N 37916) on outer face of rubber so studs on mount weldment are going through the holes in clamp plate. Ensure that hole in clamp plate is oriented upward.

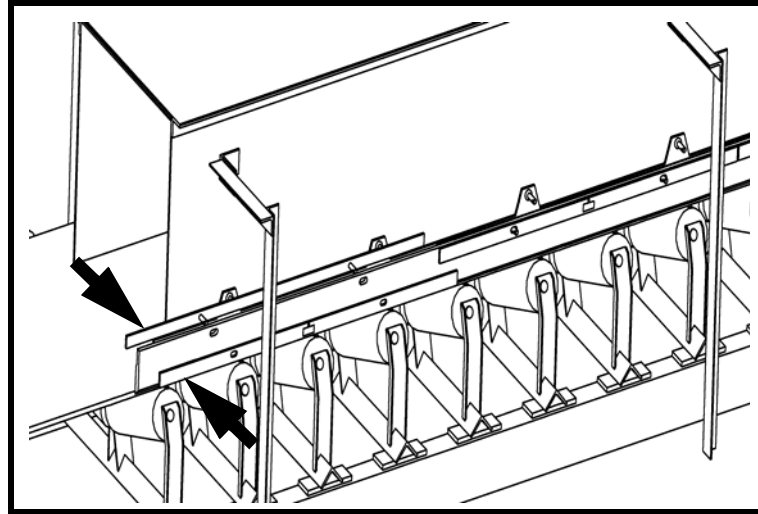

Figure 7a. Placing Rubber Skirting over Pins

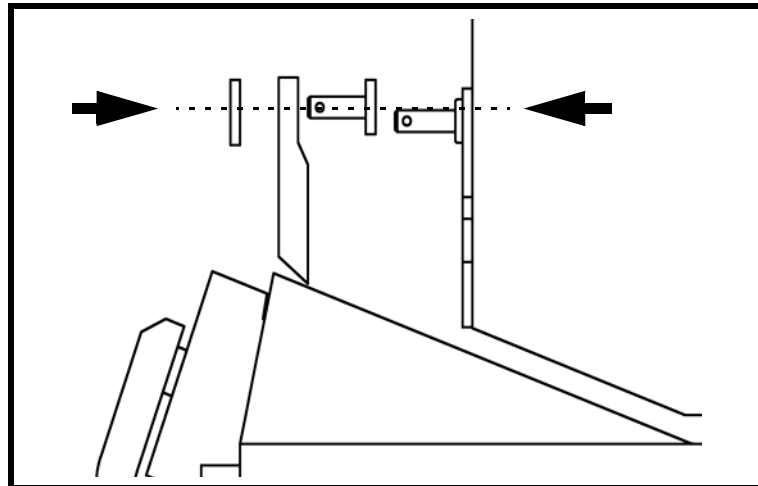

Figure 7b. Placing Rubber Skirting over Pins

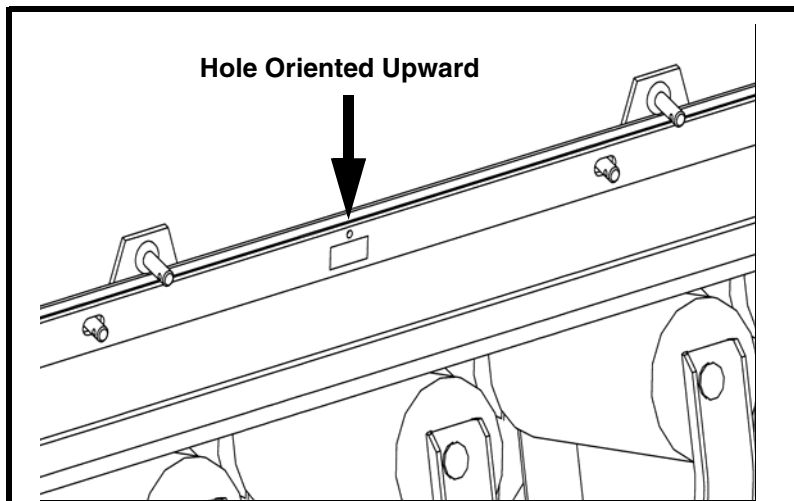

Figure 7c. Placing Rubber Skirting over Pins

15. Slide pressure arms (P/N 37917) over studs on back plate and mount plate. It may be necessary to slide skirting from side to side to allow arms to line up with studs.

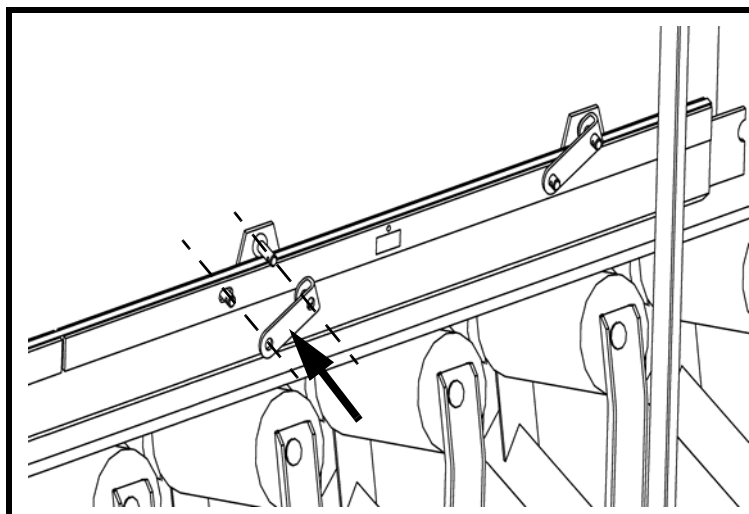
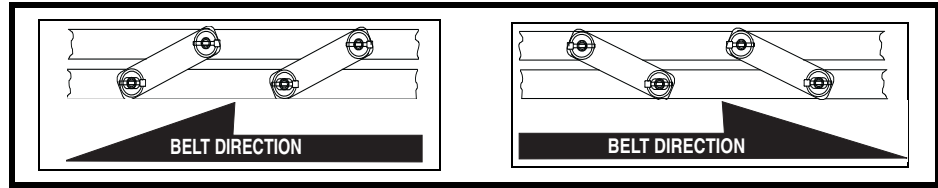

Figure 8. Lining Up Holes in Pressure Arms

IMPORTANT

Pressure arms must be oriented to allow rubber to float on belt.



- 16. Secure pressure arms with linchpins (P/N 37111). Be sure pressure arms are oriented to allow rubber to float on belt.
- 17. Repeat steps 13–16 on other side of belt.

⚠ WARNING

Martin® Self Adjusting Skirting is designed to operate on single-direction belts. Use on reversing belts or belts that roll back could result in a brake action that could lock the belt and create a latent energy hazard.



⚠ DANGER

Do not attempt to adjust or clear jammed materials from the Martin® Self Adjusting Skirting while belt is in operation. Serious injury or death may result from being caught between the moving belt and skirting or idlers.

After Installing Skirting

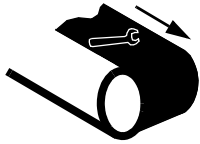

⚠ WARNING

Failure to remove tools from maintenance area and conveyor belt before turning on energy source can cause serious injury to personnel and damage to belt.

1. Make sure all fasteners and welds are secure. Re-weld or secure as necessary
2. Remove all tools from installation area. Turn on conveyor belt for 1 hour, and then turn off.
3. Make sure all fasteners and welds are secure. Re-weld or secure as necessary.
4. Remove all tools from installation area.

Maintenance



IMPORTANT

Read entire section before beginning work.

⚠ WARNING

Before inspecting equipment, lock out/tag out energy source to conveyor and conveyor accessories.

⚠ DANGER

Do not attempt to make the skirt float or remove jammed material while the belt is running. Serious injury or death may result.

1. Periodically observe the action of the skirting. When performing routine, scheduled clean-up, hose down the skirting or otherwise clean it to insure free-floating action.
2. Clean accumulated buildup or jammed material as required for free-floating operation.
3. Check the floating action of the skirt monthly by prying between the belt and the skirt rubber in several places with a pry bar.
4. Replace the skirt rubber with new rubber before the arms are perpendicular to the belt and there is no ability of the system to adjust for wear.
5. Replace worn or broken components when needed to maintain the free-floating action without excessive side movement.
6. Remove equipment from service if there is any indication it is not functioning properly. Call Martin Engineering or representative for assistance. Do NOT return equipment to operation until the cause of the problem has been identified and corrected.
7. Wipe all labels clean. If labels are not readable, contact Martin Engineering or representative for replacements.

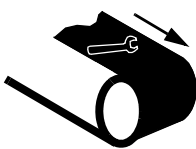

⚠ WARNING

Failure to remove tools from maintenance area and conveyor belt before turning on energy source can cause serious injury to personnel and damage to belt.

8. Remove all tools from maintenance area.

Part Numbers

This section provides part numbers for Martin[®] Self Adjusting Skirting and related equipment. Please reference part numbers when ordering parts.

Martin[®] Self Adjusting Skirting

Martin[®] Self Adjusting Skirting Assembly: P/N 37911-XX

Martin[®] Self Adjusting Skirting Assembly: P/N 37911-SS

Martin[®] Wear Liners

P/N WL-XXXXXXXXXXXX. First four Xs indicate the height of wear liner in inches; next four Xs indicate length of wear liner in inches; next three Xs indicate thickness of wear liner in inches; last X indicates wear liner material.

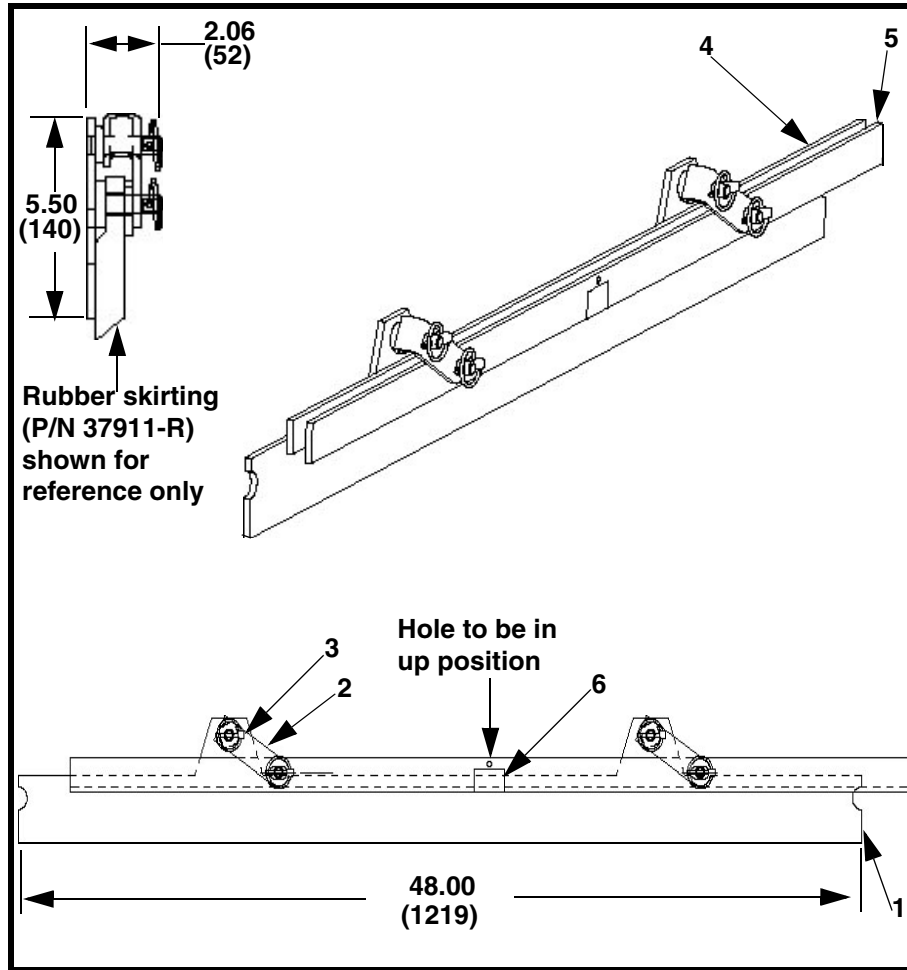

Figure 9. Martin[®] Self Adjusting Skirting Assembly, P/N 37911-XX

Item	Description	Part No.	Qty.
1	Back Plate Weldment	Table II	1
2	Pressure Arm (Zinc Plated)	37917-P	2
3	Linchpin 3/16 x 1-1/4	37111	4
4	Mount Weldment	37915	1
5	Clamping Plate	37916	1
6	Martin Product Label*	32238	1

*Apply Martin[®] Product Label centered under hole.

- Notes:
1. All dimensions are given in inches (mm).
 2. All inch dimensions are $\pm .06$ unless otherwise specified.
 3. (MM) are shown for reference purposes only. Actual (mm) values and tolerances should be derived from inch values given.

Table II. Part Numbers for Martin® Self Adjusting Skirting Assembly, P/N 37911-XX

Assembly Part Number	Part No. Item 1
37911	37912
37911-AR	37912-AR

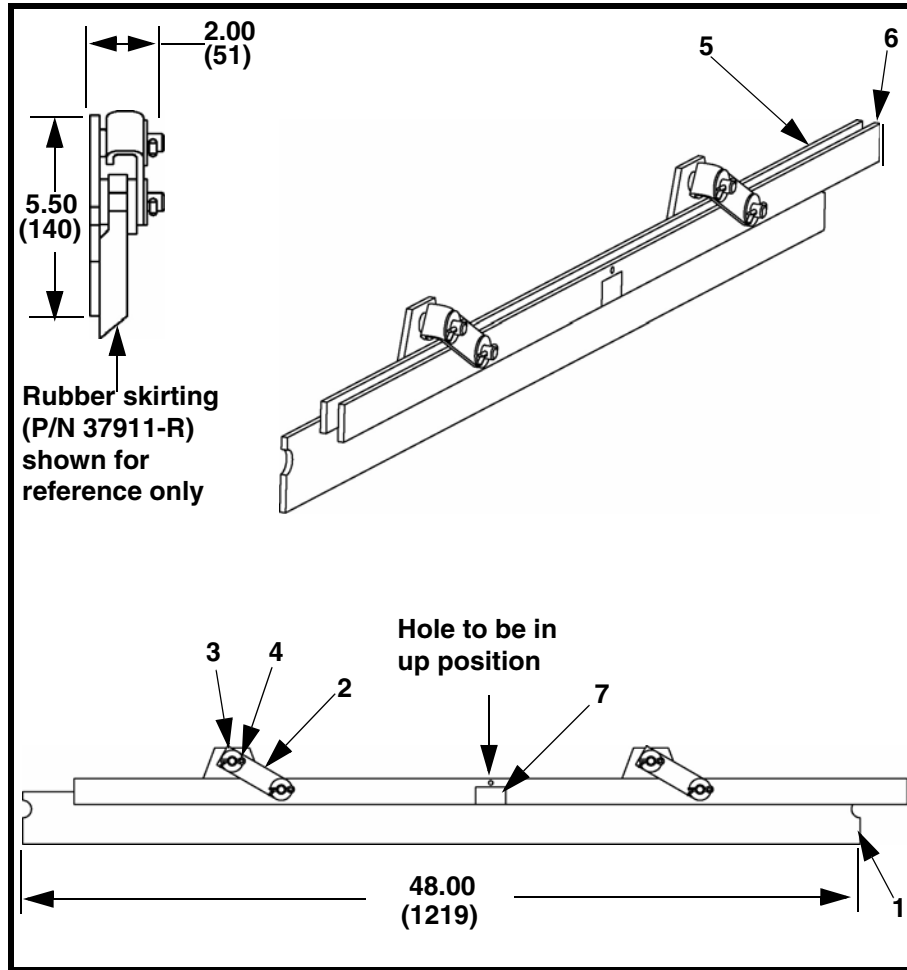

Figure 10. Martin[®] Self Adjusting Skirting Assembly, P/N 37911-SS

Item	Description	Part No.	Qty.
1	Back Plate Weldment SS	37912-SS	1
2	Pressure Arm SS	37917-SS	2
3	Flat Washer 1/2 SS	35913	4
4	Cotter Pin 3/16 x 1 316 SS	31293-316SS	4
5	Mount Weldment SS	37915-SS	1
6	Clamping Plate SS	37916-SS	1
7	Martin Product Label*	32238	1

*Apply Martin[®] Product Label centered under hole.

- Notes:
1. All dimensions are given in inches (mm).
 2. All inch dimensions are $\pm .06$ unless otherwise specified.
 3. (MM) are shown for reference purposes only. Actual (mm) values and tolerances should be derived from inch values given.

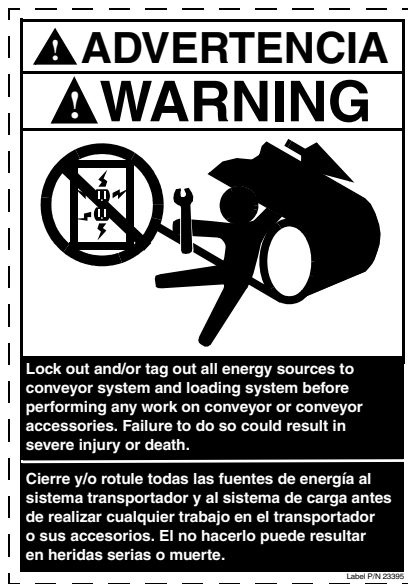

Figure 11. Conveyor Products Warning Label, P/N 23395

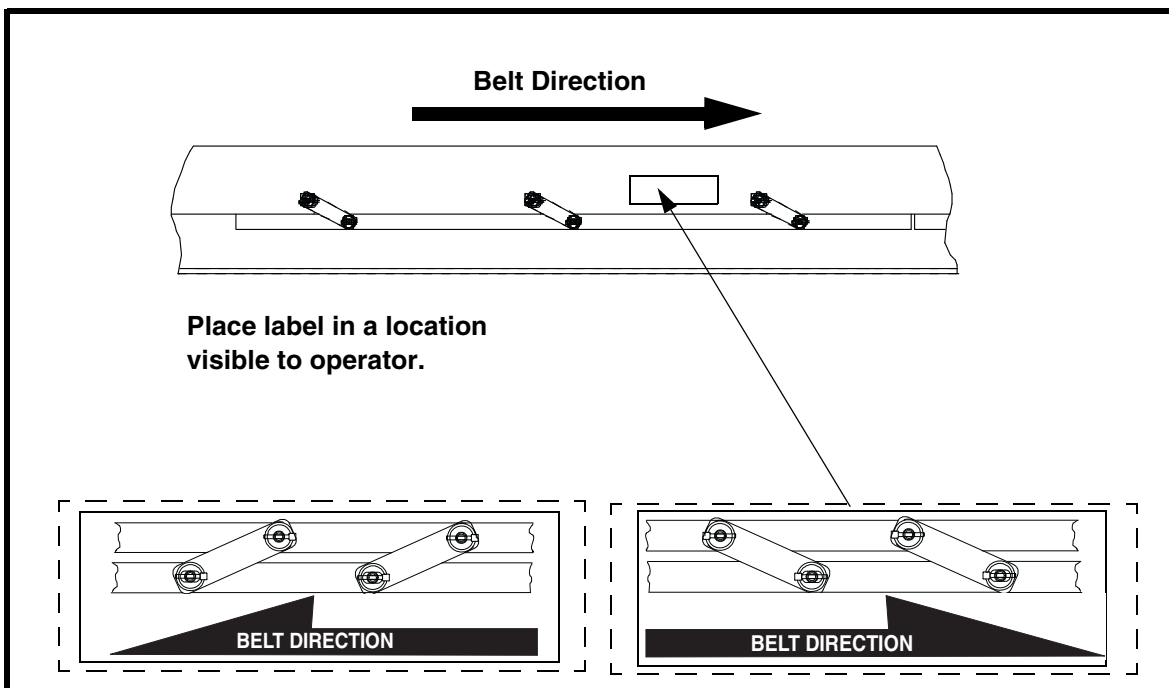
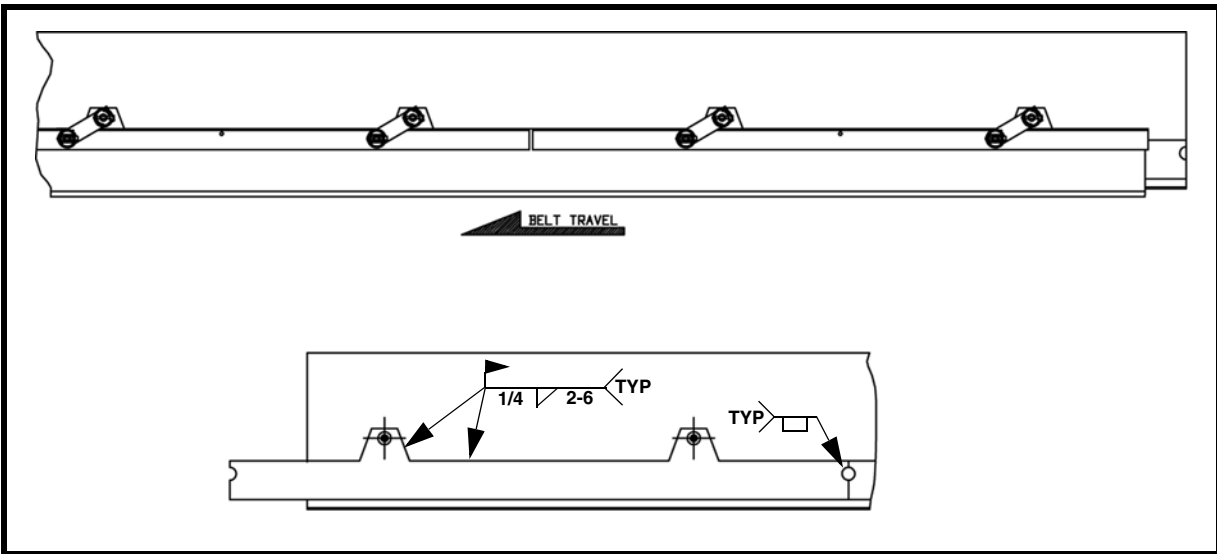
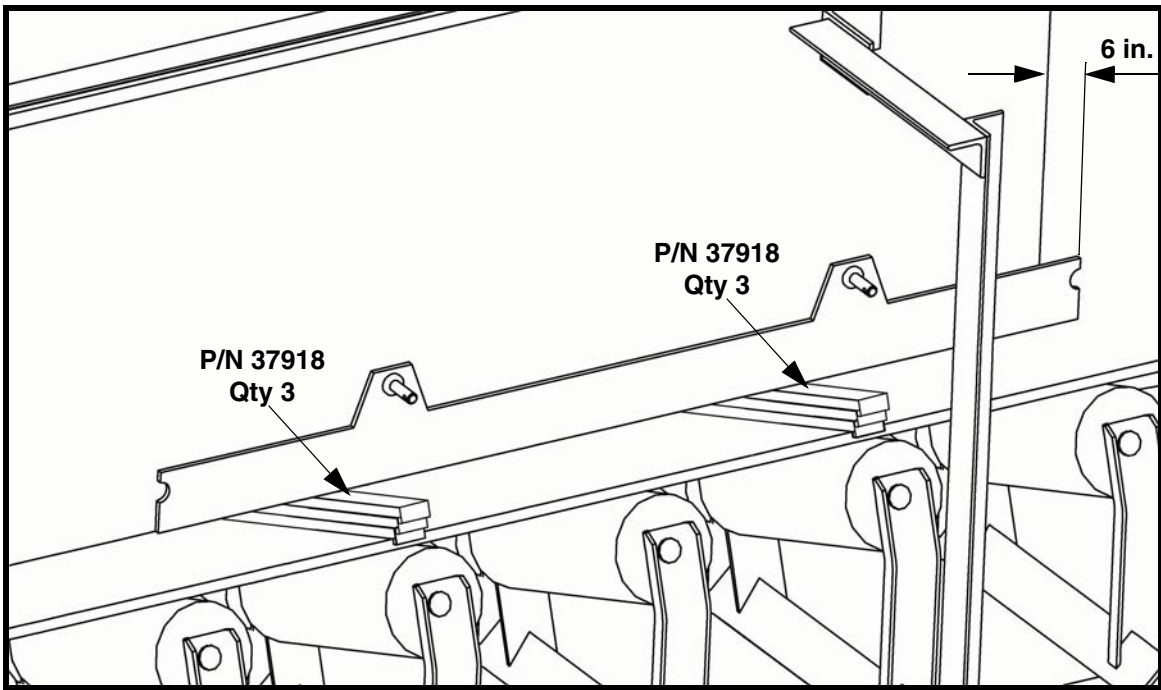

Figure 12. Belt Direction Label Placement

Notes

Appendix
Martin® Self Adjusting Interior Skirting Installation



Martin® Self Adjusting Interior Skirting

Installation Notes:

1. The lower 6.50 in. (165 mm) of outside surface of chute wall must be smooth to properly install this equipment.
2. Refer to drawing above for proper installation tool placement when installing back plate. Refer to “Installing Skirting” steps 3–12 for general installation procedures.
3. Assemble rubber skirting between mount weldment and clamping plate through studs on mount weldment. Lower floating edge onto the belt. This assembly of components will then be attached to pressure arms from behind, by inserting studs into vacant holes in pressure arms. Pin in place using lynch pins.
4. All dimensions given in inches (mm) and are for reference only.

5. A minimum clearance of 7.0 in. (178 mm) vertically and 2.25 in.(57 mm) horizontally is required to install skirting assembly.
6. Skirting should begin at least 6.0 in. (305 mm) after exit side of chute wall.
7. To provide an effective seal, Martin® Wear Liners are recommended.
8. Consult Martin Engineering for installations with unusual or severe conditions, such as: concave/convex curves, extreme side pressure, unusually slow or fast belts, temperature extremes, etc.

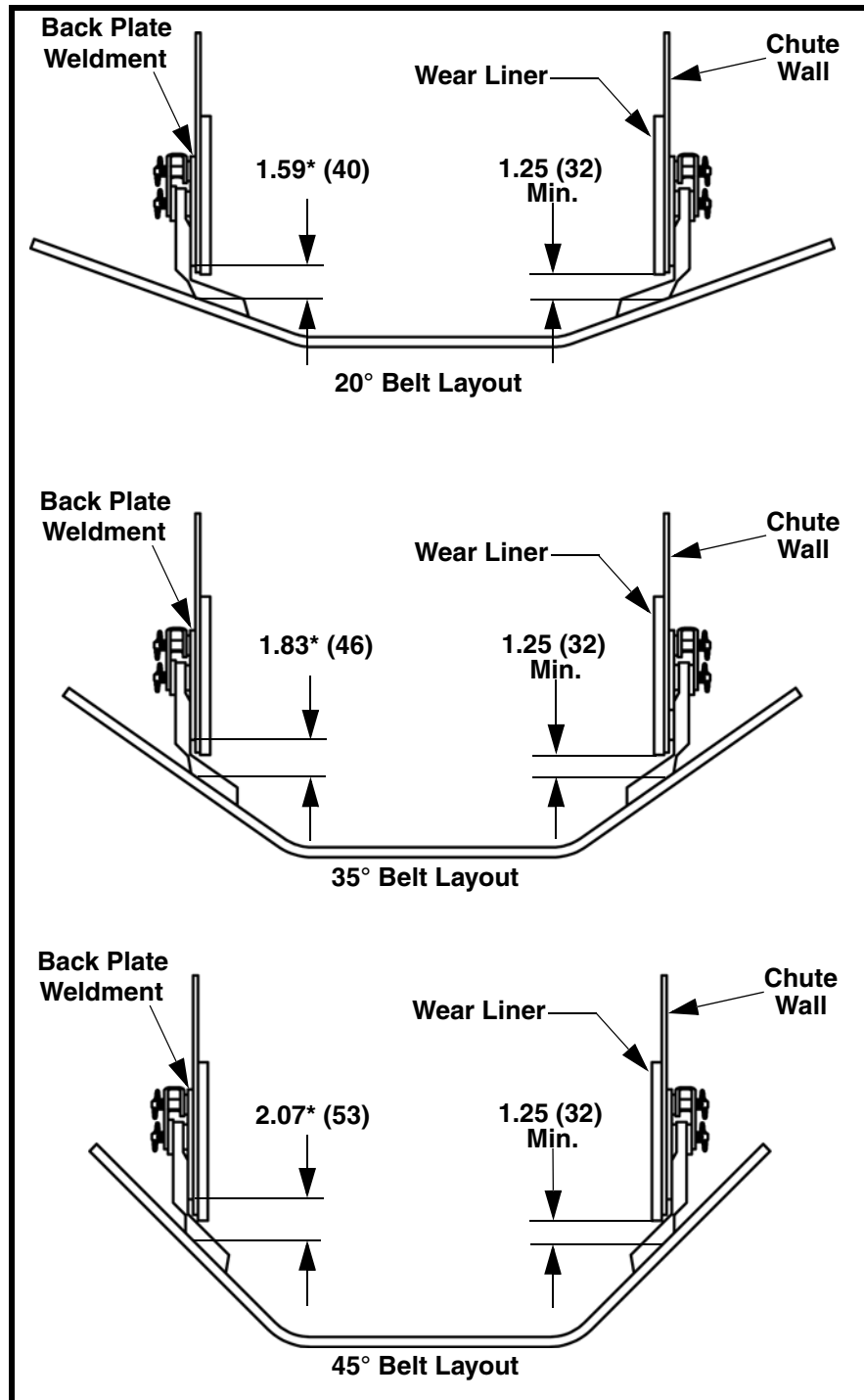

*Measurement is from the top of belt to the bottom of back plate weldment, P/N 37912.

Back Plate Weldment Mounting

Notes

Any product, process, or technology described here may be the subject of intellectual property rights reserved by Martin Engineering Company. Trademarks or service marks designated with the ® symbol are registered with the U.S. Patent and Trademark Office and may be proprietary in one or more countries or regions. Other trademarks and service marks belonging to Martin Engineering Company in the United States and/or other countries or regions may be designated with the “TM” and “SM” symbols. Brands, trademarks, and names of other parties, who may or may not be affiliated with, connected to, or endorsed by Martin Engineering Company, are identified wherever possible. Additional information regarding Martin Engineering Company’s intellectual property can be obtained at www.martin-eng.com/trademarks.

Problem Solved™
GUARANTEED!



Martin Engineering USA

One Martin Place
Neponset, IL 61345-9766 USA
800 544 2947 or 309 852 2384
Fax 800 814 1553
www.martin-eng.com

**COMPANY WITH
QUALITY SYSTEM
CERTIFIED BY DNV
= ISO 9001:2008 =**