

# Cougar® AP5 Series Piston Vibrators

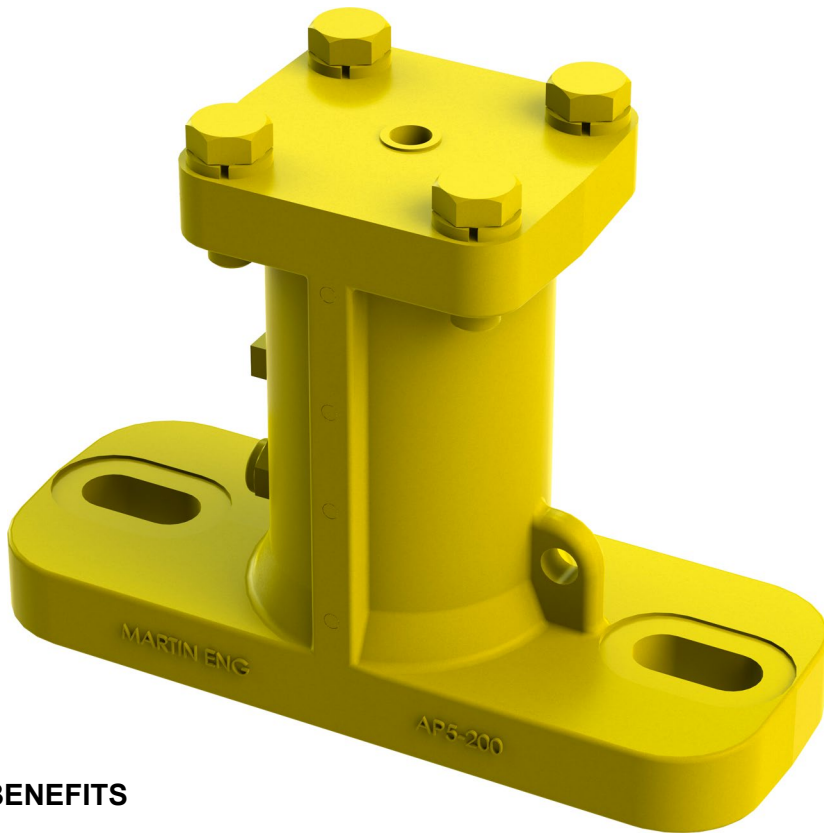

## BENEFITS

- **Economical**  
Low initial cost, plus cost savings by eliminating the pounding, poking, and hammering of hoppers, ensures material flow with cost savings.
- **Minimal Maintenance**  
Limited maintenance required for life of the vibrator when used with a filtered and lubricated air supply.
- **Versatility**  
Variable control of force and frequency to meet a variety of material conditions.
- **Slotted Mounting Holes**  
The AP5-200 can be a bolt in direct replacement for nearly all 2" piston vibrators in the marketplace.
- **Exhaust Mufflers**  
The AP5-200 comes standard with exhaust mufflers to attenuate the exhaust noise and aid in preventing dust and dirt from entering the vibrator.

## FEATURES

- Alloy steel bodies
- Hardened pistons
- Low air consumption
- Produces uniform directional force
- Optional
  - internal spring for positive starting
  - manifold/muffler for quiet operation
  - air cushioned non-impacting
  - universal mount
  - high temperature up to 400°F

## Specify Cougar for:

- Cost effective solutions
- Expert technical assistance
- Complete service and support

# TECHNICAL DATA SHEET

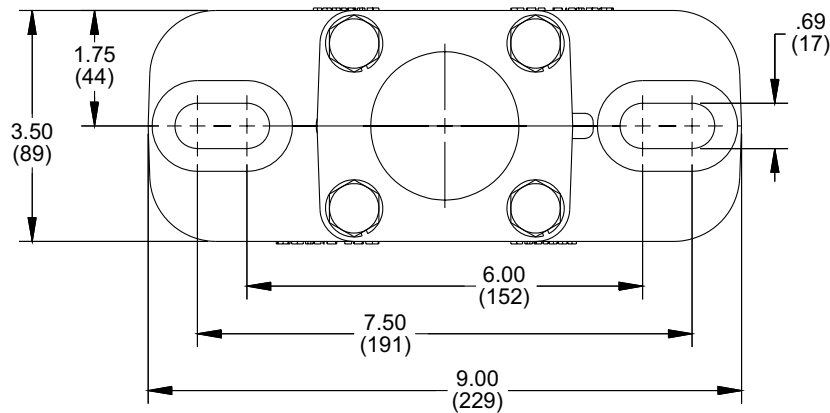
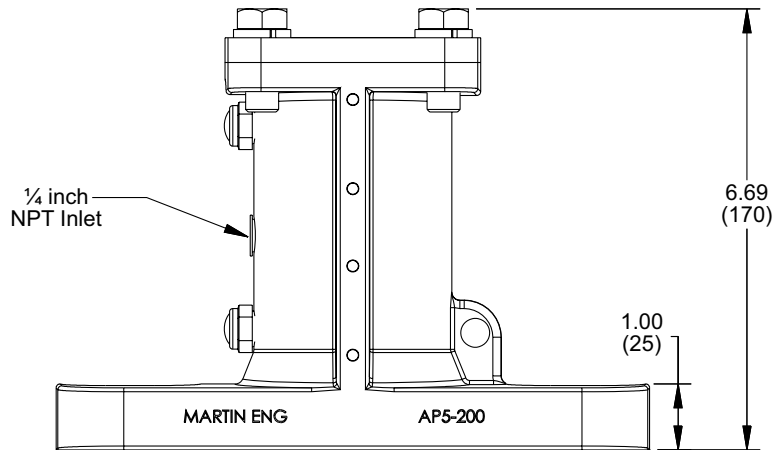

## PERFORMANCE DATA

Model	Piston Size In.	40 PSI			60 PSI			MAX 80 PSI			dB
		VPM	CFM	Force lb	VPM	CFM	Force lb	VPM	CFM	Force lb	
AP5-200	2	2640	9	504	3180	14	731	3600	18	937	103
AP5-200Q	2	2284	7.7	336	2240	9.8	510	2800	14	628	87



**Martin Engineering USA**  
 One Martin Place  
 Neponset, IL 61345-9766 USA  
 800 544 2947 or 309 852 2384  
 Fax 800 814 1553  
[www.martin-eng.com](http://www.martin-eng.com)

**COMPANY WITH  
 QUALITY SYSTEM  
 CERTIFIED BY DNV  
 = ISO 9001:2008 =**

**COUGAR**  
**VIBRATION SOLUTIONS**

**Problem Solved™ GUARANTEED!**

Form No. L4018-09/15  
 © Martin Engineering Company 2014, 2015