

Sealing System Selection Guide

| Skirting Type | P/N | Material | Durometer Shore A | Max. Order Length** | Max. Belt Speed*** | Temp. Range |
|---|-------------|-------------------|-------------------|---------------------|--------------------|-------------------------------|
| SKIRTING SYSTEMS | | | | | | |
| MARTIN® APRON SEAL™ Standard 1-Piece Skirting | 100724 | EPDM Rubber | 70 | 300' | 600 | -20° to 250°F (-29° to 121°C) |
| MARTIN® APRON SEAL™ Standard 1-Piece Skirting | 100724-0660 | EPDM Rubber | 60 | 300' | 600 | -20° to 250°F (-29° to 121°C) |
| MARTIN® APRON SEAL™ High-Temp 1-Piece Skirting* | 100724-XXH | High-Temp Rubber | 80 | 12' & 24' | 700 | -70° to 400°F (-57° to 204°C) |
| MARTIN® APRON SEAL™ Food-Grade 1-Piece Skirting* | 100724-XXF | Food-Grade Rubber | 65 | 12' & 24' | 600 | -70° to 275°F (-57° to 135°C) |
| MARTIN® APRON SEAL™ Heavy-Duty 1-Piece Skirting | 100723 | EPDM Rubber | 70 | 300' | 750 | -20° to 250°F (-29° to 121°C) |
| MARTIN® APRON SEAL™ Heavy-Duty 1-Piece Skirting | 100808 | EPDM Rubber | 70 | 300' | 750 | -20° to 250°F (-29° to 121°C) |
| MARTIN® APRON SEAL™ Heavy-Duty 1-Piece Skirting | 100808-60 | EPDM Rubber | 60 | 300' | 750 | -20° to 250°F (-29° to 121°C) |
| MARTIN® APRON SEAL™ Heavy-Duty-M 1-Piece Skirting* | 100723-XXM | MSHA-Approved | 60 | 300' | 750 | -20° to 250°F (-29° to 121°C) |
| MARTIN® APRON SEAL™ Extra Heavy-Duty 1-Piece Skirting | 100845 | EPDM Rubber | 60 | 200' | 750 | -20° to 250°F (-29° to 121°C) |
| MARTIN® Double APRON SEAL™ Standard Skirting | 100873 | EPDM Rubber | 70 | 300' | 600 | -20° to 250°F (-29° to 121°C) |
| MARTIN® Double APRON SEAL™ Heavy-Duty Skirting | 100861 | EPDM Rubber | 70 | 300' | 750 | -20° to 250°F (-29° to 121°C) |
| MARTIN® BOCO™ Self-Adjusting Skirting | 37911-R | EPDM Rubber | 70 | 100' | 600 | -20° to 250°F (-29° to 121°C) |
| REPLACEMENT RUBBER | | | | | | |
| Rubber Secondary* | 100746 | SBR Rubber | 75 | 300' | 600 | -20° to 250°F (-29° to 121°C) |
| DCI Replacement* | 100736 | SBR Rubber | 75 | 300' | 600 | -20° to 250°F (-29° to 121°C) |
| ARGONICS SNAP-LOC™ Dust Seal Replacement* | 100792 | SBR Rubber | 60 | 300' | 600 | -20° to 250°F (-29° to 121°C) |

Notes: Part Numbers with XX: Replace "XX" with 12 or 24 for skirt length. * Skirting System Not Shown. ** Order by 1-foot increments up to 300-foot lengths, except those noted 12 and 24 foot only. *** If your belt speed exceeds what is listed above, please contact Martin Engineering.

Free Belt Area: Space between the outside chute wall and the edge of the conveyor belt. Information given assumes there is no belt wander.

Trough Angle: The angle at which the belt edges are elevated to carry the material load.

Wear Liner: Martin Engineering recommends the use of properly installed wear liner inside the chute to protect the skirting system.

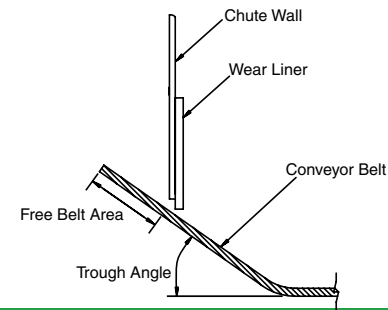

**MARTIN® APRON SEAL™
1-Piece Skirting System**

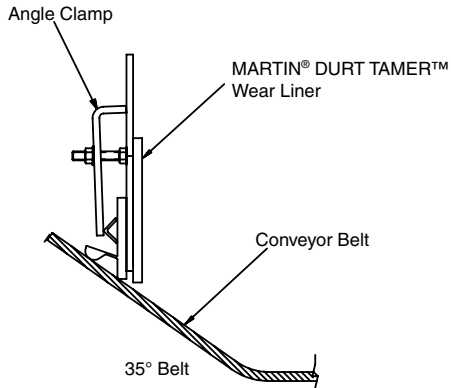

**MARTIN® APRON SEAL™
Heavy-Duty and Extra Heavy-Duty
1-Piece Skirting Systems**

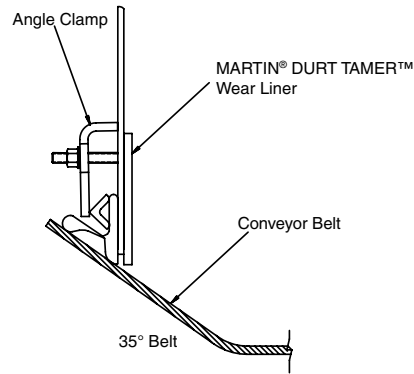

**MARTIN® Double APRON SEAL™
Skirting System**

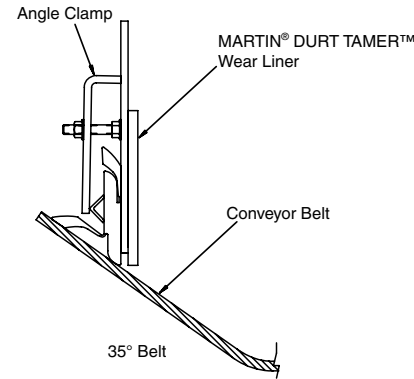

**MARTIN® BOCO™
Self-Adjusting Skirting System**

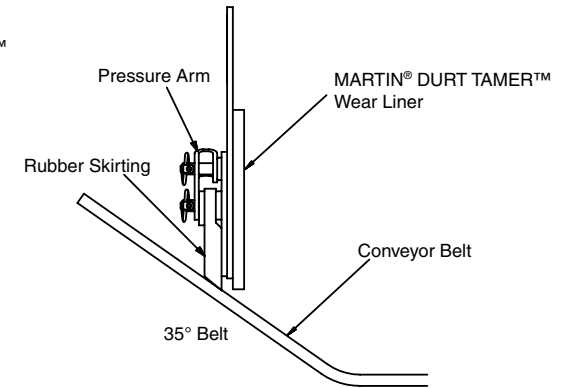

MINIMUM FREE BELT AREA—IN. (MM)

| Trough Angle | MARTIN® APRON SEAL™ Skirting | | | | | MARTIN® BOCO™ Self-Adjusting Skirting |
|--------------|------------------------------|--------------------|--------------------------|-----------------|-------------------|---------------------------------------|
| | Standard 1-Piece | Heavy-Duty 1-Piece | Extra Heavy-Duty 1-Piece | Standard Double | Heavy-Duty Double | |
| 0° | 2.14 (54) | 2.97 (76) | 3.50 (89) | 2.14 (54) | 2.97 (76) | 1.50 (38) |
| 20° | 2.58 (66) | 3.74 (95) | 4.25 (108) | 2.58 (66) | 3.74 (95) | 1.50 (38) |
| 35° | 2.87 (73) | 4.18 (106) | 4.75 (121) | 2.87 (73) | 4.18 (106) | 1.50 (38) |
| 45° | 3.01 (77) | 4.38 (111) | 5.00 (127) | 3.01 (77) | 4.38 (111) | 1.50 (38) |



MARTIN ENGINEERING USA
One Martin Place
Neponset, IL 61345-9766 USA
info@martin-eng.com
www.martin-eng.com

SNAP-LOC™ is a trademark of Argonics, Inc., Maquette, MI. U.S.A.
who is not affiliated with Martin Engineering in any way.

800-544-2947 or 309-852-2384

THE THINK CLEAN® COMPANY

Patents and patents pending. ® Registered trademark of Martin Engineering Company in the US and other select locations. © 2010 Martin Engineering Company.