



***BIG BLASTER®
XHV Air Cannon
with MARTIN® TORNADO Exhaust Valve***

[Go to BIG BLASTER® XHV Air Cannon with MARTIN® TORNADO Exhaust Valve web page](#)



***Operator's Manual
M3754***

Important

MARTIN ENGINEERING HEREBY DISCLAIMS ANY LIABILITY FOR: DAMAGE DUE TO CONTAMINATION OF THE MATERIAL; USER'S FAILURE TO INSPECT, MAINTAIN AND TAKE REASONABLE CARE OF THE EQUIPMENT; INJURIES OR DAMAGE RESULTING FROM USE OR APPLICATION OF THIS PRODUCT CONTRARY TO INSTRUCTIONS AND SPECIFICATIONS CONTAINED HEREIN. MARTIN ENGINEERING'S LIABILITY SHALL BE LIMITED TO REPAIR OR REPLACEMENT OF EQUIPMENT SHOWN TO BE DEFECTIVE.

Observe all safety rules given herein along with owner and Government standards and regulations. Know and understand lockout/tagout procedures as defined by American National Standards Institute (ANSI) z244.1-1982, *American National Standard for Personnel Protection - Lockout/Tagout of Energy Sources - Minimum Safety Requirements* and Occupational Safety and Health Administration (OSHA) Federal Register, Part IV, 29 CFR Part 1910, *Control of Hazardous Energy Source (Lockout/Tagout); Final Rule*.

The following symbols may be used in this manual:



Danger: Immediate hazards that will result in severe personal injury or death.



Warning: Hazards or unsafe practices that could result in personal injury.



Caution: Hazards or unsafe practices that could result in product or property damages.



Important: Instructions that must be followed to ensure proper installation/operation of equipment.



Note: General statements to assist the reader.

Table of Contents

Section	Page
List of Figures	ii
Introduction	1
General	1
Operation	1
Tank data	2
Serial and model numbers	2
Specifications	2
Required accessories	3
References	3
Safety	3
Materials required	3
Before Installing Air Cannon	4
Installing Air Cannon	6
Installing mounting plate	6
Connecting air cannon to mounting plate	10
Installing restraining cable	11
Connecting air supply to air cannon	12
After Installing Air Cannon	17
Maintenance	19
Every month	19
Every year or 50,000 firings	20
Troubleshooting	21
Part Numbers	22
Appendix A. BIG BLASTER [®] XHV Air Cannon with MARTIN [®] TORNADO Exhaust Valve Specifications and Performance Data	A-1

List of Figures

Figure	Title	Page
1	Air Cannon Charging and Discharging	1
2	Serial and Model Number Plate	2
3	Installing 30-Degree Mounting Plate	7
4	Installing a Drop-Through 30-Degree Mounting Plate for Vessels with Liner.	7
5	Mounting Nozzles/Pipes for High-Temperature Applications	8
6	Installing Stainless Steel Blow Pipe and Carbon Steel Blow Pipe for High-Temperature Applications	8
7	Installing Straight Stainless Steel Fan Nozzle and Carbon Steel Pipe for High-Temperature Applications	9
8	Riser Duct with Fan Nozzles for High-Temperature Applications.	9
9	Installing 90-Degree Stainless Steel Nozzle for High-Temperature Applications	10
10	Cyclone with High-Temperature Blow Pipes	10
11	Installing Restraining Cable	11
12	Plumbing Detail for Normally-Opened Solenoid Valve	15
13	Plumbing Detail for Normally-Closed Solenoid Valve.	16
14	BIG BLASTER [®] XHV Air Cannon with MARTIN [®] TORNADO 2” Exhaust Valve Assembly, P/N 37864-XXXX.	23
15	BIG BLASTER [®] XHV Air Cannon with MARTIN [®] TORNADO 4” Exhaust Valve Assembly, P/N 37798-XXXX.	24
16	BIG BLASTER [®] XHV Air Cannon with MARTIN [®] TORNADO 6” Exhaust Valve Assembly, P/N 37853-XXXX.	25
17	MARTIN [®] TORNADO 2” Exhaust Valve Assembly Parts List, P/N 37984	26
18	MARTIN [®] TORNADO 4” Exhaust Valve Assembly Parts List, P/N 37985	27
19	MARTIN [®] TORNADO 6” Exhaust Valve Assembly Parts List, P/N 37986	28
20	Air Cannon Warning Label, P/N 33439	29
21	BIG BLASTER [®] Serial/Model Number Label, P/N 21313	29
22	Air Blast Warning Label, P/N 31913	30
23	Loud Noise Warning Tag, P/N 34070	31

Introduction

General

The BIG BLASTER[®] XHV Air Cannon with MARTIN[®] TORNADO Exhaust Valve is a pneumatic bulk material-moving system that quickly releases compressed air into storage vessels, transfer chutes, gas ducts, and feed pipes to maintain material or gas flow.

This manual provides instructions for installing air cannons on steel structures only. For installations on other structures, call Martin Engineering or representative.

Operation

The BIG BLASTER[®] XHV Air Cannon with MARTIN[®] TORNADO Exhaust Valve System consists of one or more air cannons mounted on a storage or process vessel. The air cannon charges when the tank is filled with compressed air or nitrogen between 10 psi and 125 psi operating pressure (up to 150 psi available upon request). When the tank pressure equals the line pressure, airflow is static and the air cannon is ready to be discharged. By activating the solenoid valve, a positive pressure signal is sent to the MARTIN[®] TORNADO Exhaust Valve causing it to actuate and release the pressure holding the piston. The piston is instantly forced back by the air pressure stored in the tank. The blast of air is then directed through the discharge pipe or nozzle and into the storage or process vessel.

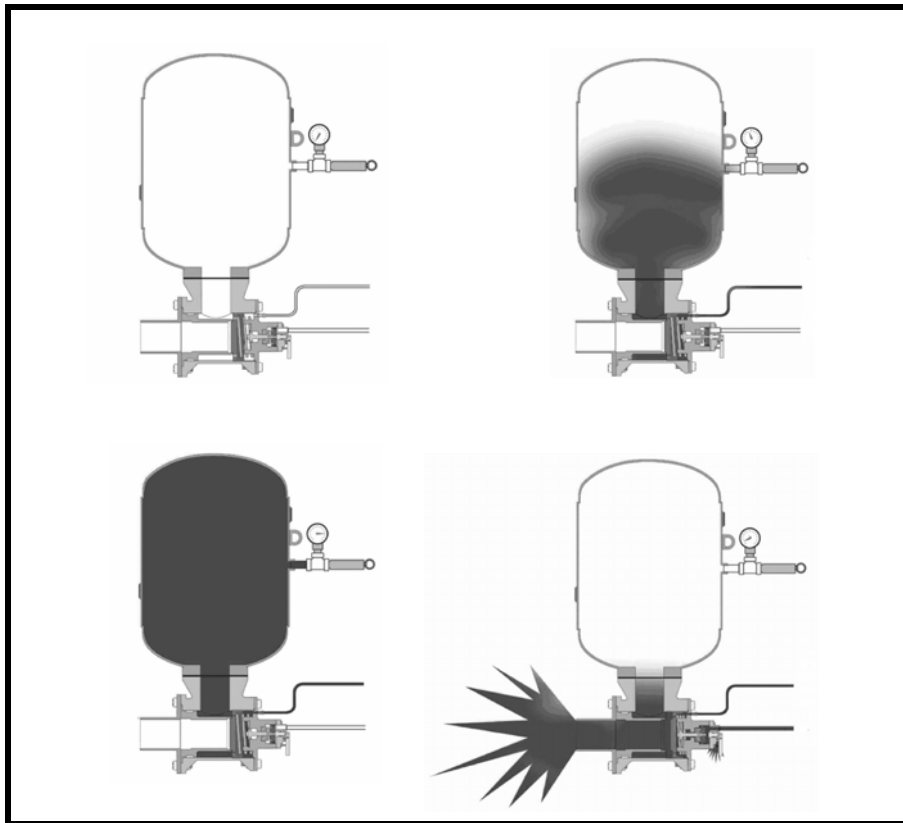

Figure 1. Air Cannon Charging and Discharging

IMPORTANT

Tank data

Never weld tank. Welding will melt paint and violate ASME coding.

The air cannon tank is manufactured to American Society of Mechanical Engineers (ASME) Code Rules, Section VIII, Division 1. It is National Board registered and is pressure vessel quality (PVQ). After the tank is welded, paint is applied inside the tank to prevent rust and corrosion. **Never weld tank.** Welding will melt paint and violate ASME coding.

Serial and model numbers

Each XHV Air Cannon’s serial and model number is shown on a plate attached to the tank (see Figure 3). Serial and model numbers must be referenced when ordering parts from Martin Engineering or representative, and on all correspondence.

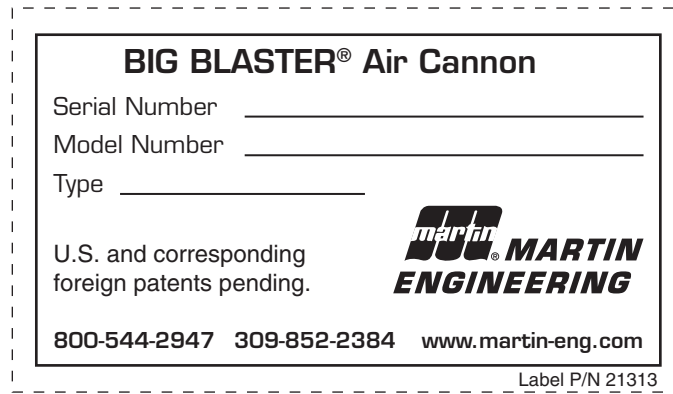

Figure 2. Serial and Model Number Plate Example

Specifications

BIG BLASTER® XHV Air Cannon with MARTIN® TORNADO Exhaust Valve

Model	Part Number
BB2-0812 XHV TORNADO	37864-0812
BB2-0820 XHV TORNADO	37864-0820
BB4-1228 XHV TORNADO	37798-1228
BB4-2030 XHV TORNADO	37798-2030
BB4-2448 XHV TORNADO	37798-2448
BB4-3060 XHV TORNADO	37798-3060
BB6-2030 XHV TORNADO	37853-2030
BB6-2448 XHV TORNADO	37853-2448
BB6-3060 XHV TORNADO	37853-3060

See Appendix A for technical data specific to individual models.

Required accessories

An air cannon system requires additional accessories in order to be fully operational. These accessories, which consist of solenoid valves, filters, regulators, air pressure gauges, ball valves, air hoses, mounting plates, nozzles, etc., can be purchased from Martin Engineering. These accessories are packaged in kits for convenience and are ordered separately from the air cannon assembly. Contact Martin Engineering or representative to determine which kits are required for your specific application.

References

The following documents are referenced in this manual:

- American National Standards Institute (ANSI) z244.1-1982, *American National Standard for Personnel Protection - Lockout/Tagout of Energy Sources - Minimum Safety Requirements*, American National Standards Institute, Inc., 1430 Broadway, New York, NY 10018.
- Federal Register, Volume 54, Number 169, Part IV, 29 CFR Part 1910, *Control of Hazardous Energy Source (Lockout/Tagout); Final Rule*, Department of Labor, Occupational Safety and Health Administration (OSHA), 32nd Floor, Room 3244, 230 South Dearborn Street, Chicago, IL 60604.
- *The National Electrical Code (NEC) Handbook*, National Fire Protection Association, 1 Batterymarch Park, P.O. Box 9101, Quincy MA 02269-9101.
- ICS 1-1988, *General Standards for Industrial Control and Systems*, and 250-1985, *Enclosures for Electrical Equipment (1000 Volts Maximum)*, National Electrical Manufacturers Association (NEMA), 2101 L Street N.W., Washington, D.C. 20037.
- *Section VIII, Rules for Construction of Pressure Vessels, Division 1*, American Society of Mechanical Engineers, United Engineering Center, 345 East 47th Street, New York, NY 10017.

Safety

All safety rules defined in the above documents, and all owner/employer safety rules, must be strictly followed when installing and servicing this equipment.

Materials required

Materials other than standard hand tools that are required to complete tasks are listed where applicable.

Before Installing Air Cannon

IMPORTANT

The delivery service is responsible for damage occurring in transit. Martin Engineering CANNOT enter claims for damages. Contact your transportation agent for more information.

1. Inspect shipping container for damage. Report damage to delivery service immediately and fill out delivery service's claim form. Keep any damaged goods subject to examination.
2. Remove air cannon assembly from shipping container. A pressure relief valve, safety restraining cable, and warning labels will be included in this container.
3. If you purchased accessories from Martin Engineering, they will be packaged separately. Remove this equipment from its shipping container.
4. Take inventory of the equipment received. If anything is missing, contact Martin Engineering or representative.

⚠ WARNING

Before installing air cannon, lock out/tag out any equipment that is loading or unloading material from the storage vessel.

5. Turn off and lock out/tag out energy source to accessory equipment according to ANSI standards (see "References").

⚠ WARNING

If equipment will be installed in an enclosed area, test gas level or dust content before using a cutting torch or welding. Using a cutting torch or welding in an area with gas or dust may cause an explosion.

6. If using a cutting torch or welding, test atmosphere for gas level or dust content.

⚠ CAUTION

When blasting into closed storage vessel, exhaust vents must be considered to prevent internal vessel air pressure from increasing to point where it may damage vessel.

7. When blasting into a closed storage vessel, exhaust vents must be considered to prevent internal vessel air pressure from increasing to the point where it may damage the vessel. See Appendix A to determine the volume of air that will be introduced into the vessel with each air cannon blast. Observe local and state codes, which may specify internal pressure limits for your vessel.

IMPORTANT

Air cannon force output can vary depending on inlet pressure, discharge opening size, structure size, material in structure, and other factors. To determine maximum force output values for your application, call Martin Engineering or representative.

8. For assistance in determining maximum force output for your application, call Martin Engineering or representative.

Installing Air Cannon

IMPORTANT

Read entire section before beginning work.

To install air cannon, follow the procedures in this section corresponding to the following steps:

1. Install mounting plate.
2. Connect air cannon to mounting plate.
3. Install restraining cable.
4. Connect air supply to air cannon. See “electrical solenoid valves” as applicable.

A variety of mount plate and nozzle designs are available from Martin Engineering. This section will describe the installation of the most commonly used mount plates and nozzles. The correct mount plate or nozzle must be used for the given application. If you are not sure which mount plate or nozzle to use for your application, contact Martin Engineering or representative.

NOTE

NOTICE OF LIMITED LIABILITY: Due to possible presence of latent structural defects in the apparatus of the purchaser, Martin Engineering shall not be responsible for consequential damage to the purchaser’s equipment and/or apparatus resulting from the application of a MARTIN® Product. Martin Engineering shall not be liable for improper installation by the purchaser or other circumstances beyond the control of Martin Engineering. Liability is disclaimed for the structural soundness of apparatus or equipment not supplied by Martin Engineering. Liability shall be strictly limited to the replacement of the purchased product or refund of the purchase price. To secure the integrity of the installation, specify supervision by qualified personnel from Martin Engineering.

Installing mounting plate

Materials required: Mounting plate or seal plate and support structure.

Material and field welds: If mild steel to mild steel use a 7018 or equivalent welding rod. If stainless steel to stainless steel, use 308 or equivalent welding rod. If stainless steel to mild steel, use 309 or equivalent welding rod.

NOTE

If you are unsure where to locate air cannon(s) on your storage vessel, contact Martin Engineering or representative.

1. Mark location for each air cannon on storage vessel.
2. A standard carbon steel mount plate or nozzle can be used for internal vessel temperatures of less than 500°F.

- a. If using 30-degree mounting plate (Figure 3), cut hole in storage vessel for each mounting plate using templates on last page of this manual. If templates are missing, contact Martin Engineering or representative. Place mounting plate over hole and field weld to vessel skin.

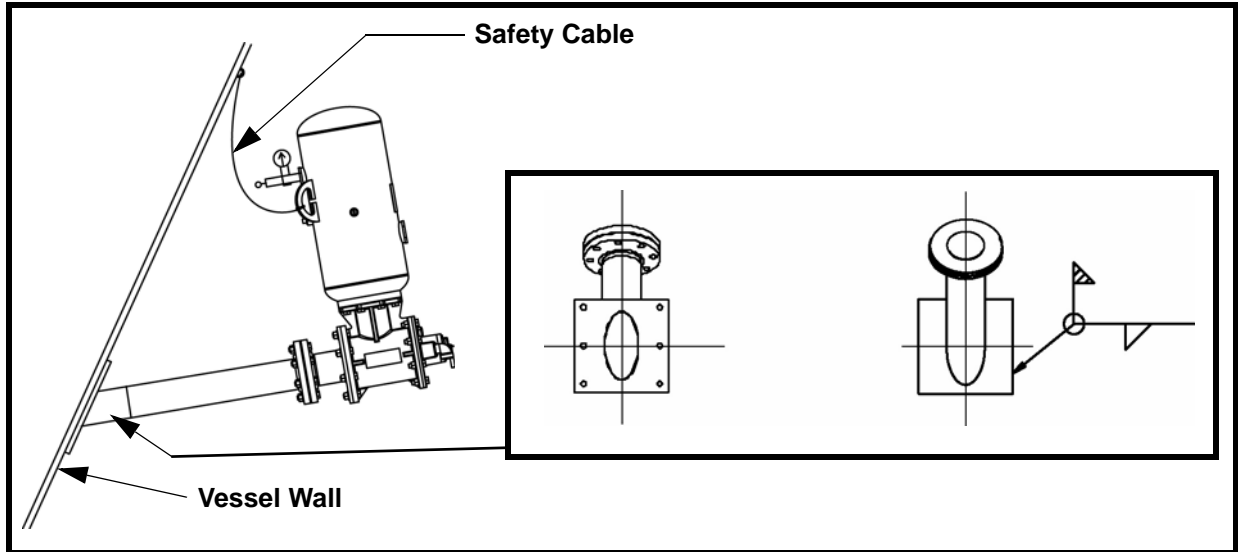

Figure 3. Installing 30-Degree Mounting Plate

- b. If mount plate is to be welded to vessel, bolt holes must be cut away or plug-welded in order to prevent air leakage upon discharge. If mount plate is to be bolted to vessel, a gasket must be used to prevent air leakage upon discharge.
- c. If vessel has a liner (Figure 4), drop-through blow-pipe must be used. The blow pipe must be extended past liner so that liner is not damaged from air cannon blast.

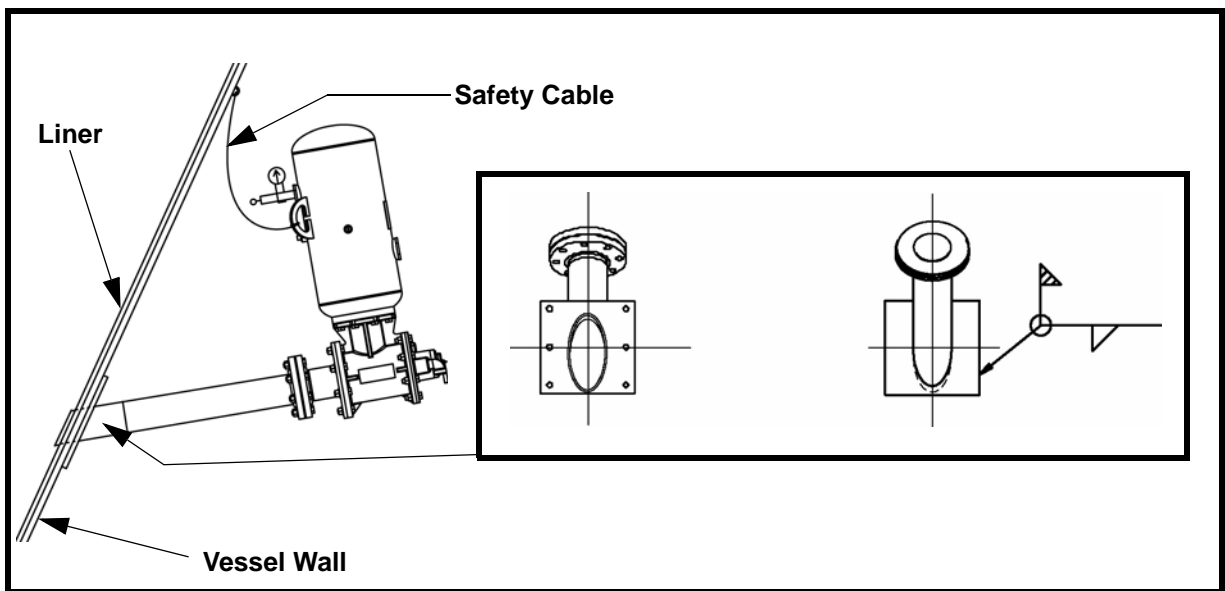

Figure 4. Installing a Drop-Through 30-Degree Mounting Plate for Vessels with Liner

3. High-temperature nozzles and blow pipes (Fig. 5) should be used in applications where the internal vessel temperature exceeds 500°F.

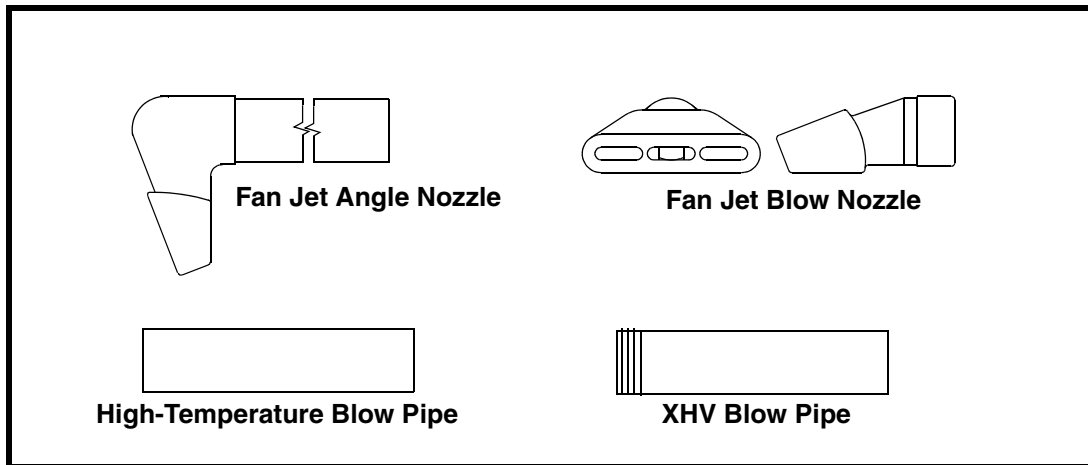

Figure 5. Mounting Nozzles/Pipes for High-Temperature Applications

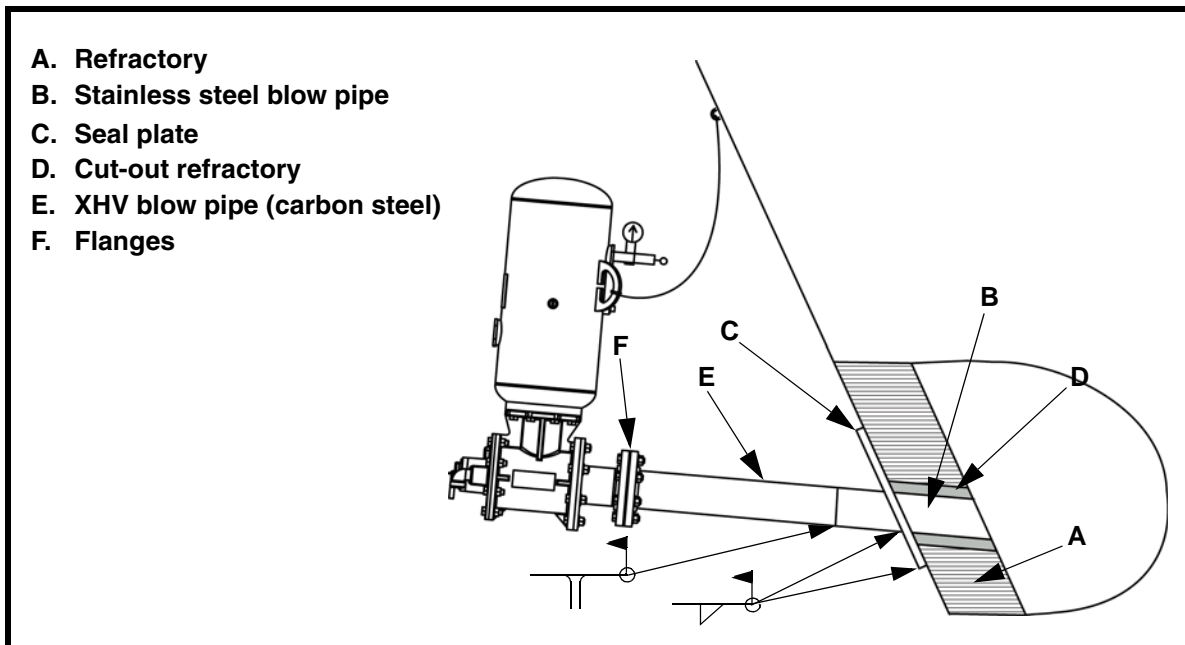

Figure 6. Installing Stainless Steel Blow Pipe and Carbon Steel Blow Pipe for High-Temperature Applications

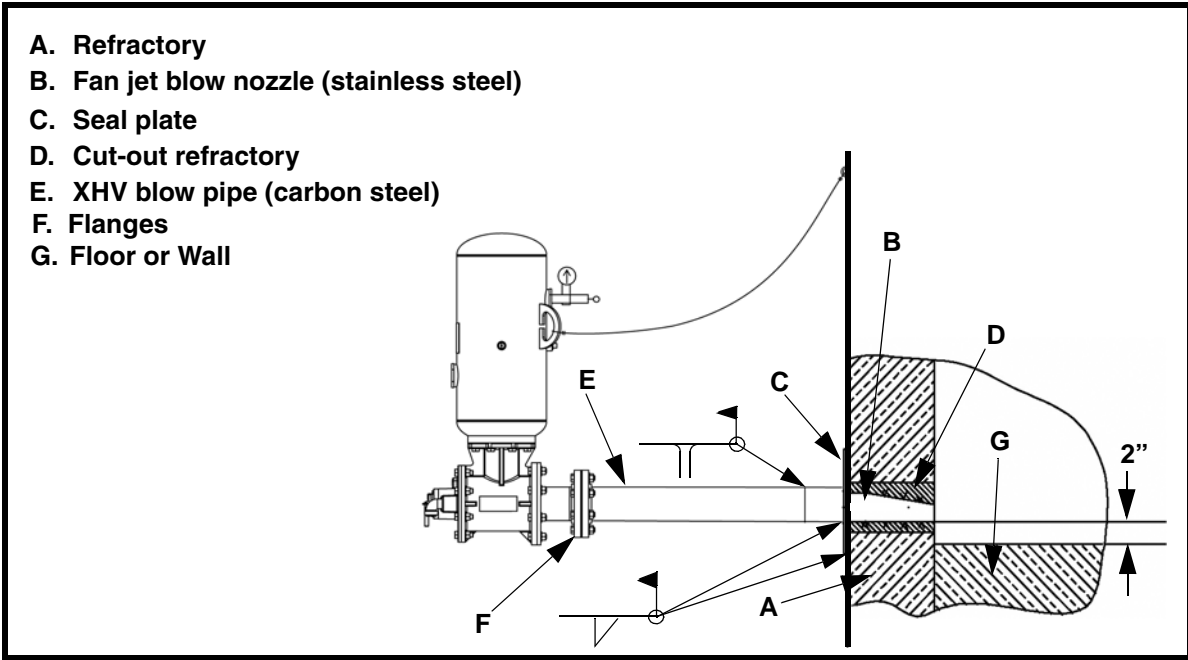

Figure 7. Installing Straight Stainless Steel Fan Nozzle and Carbon Steel Pipe for High-Temperature Applications

4. Plan view of nozzle placement for riser duct application. Alternate levels between Pattern 1 and Pattern 2 for maximum area coverage.

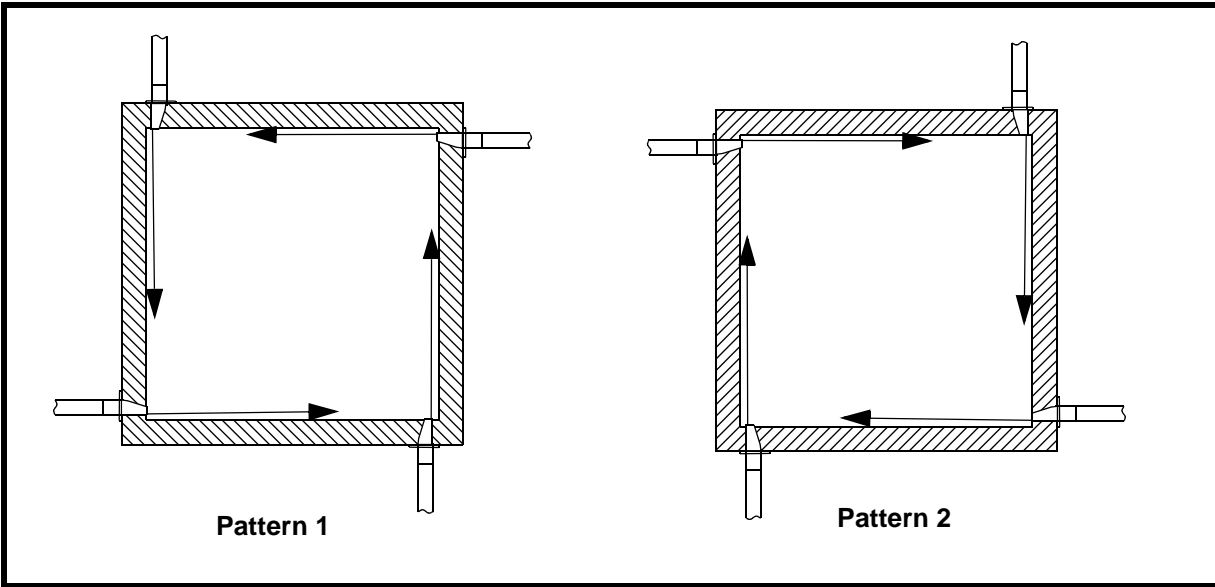

Figure 8. Riser Duct with Fan Nozzles for High-Temperature Applications

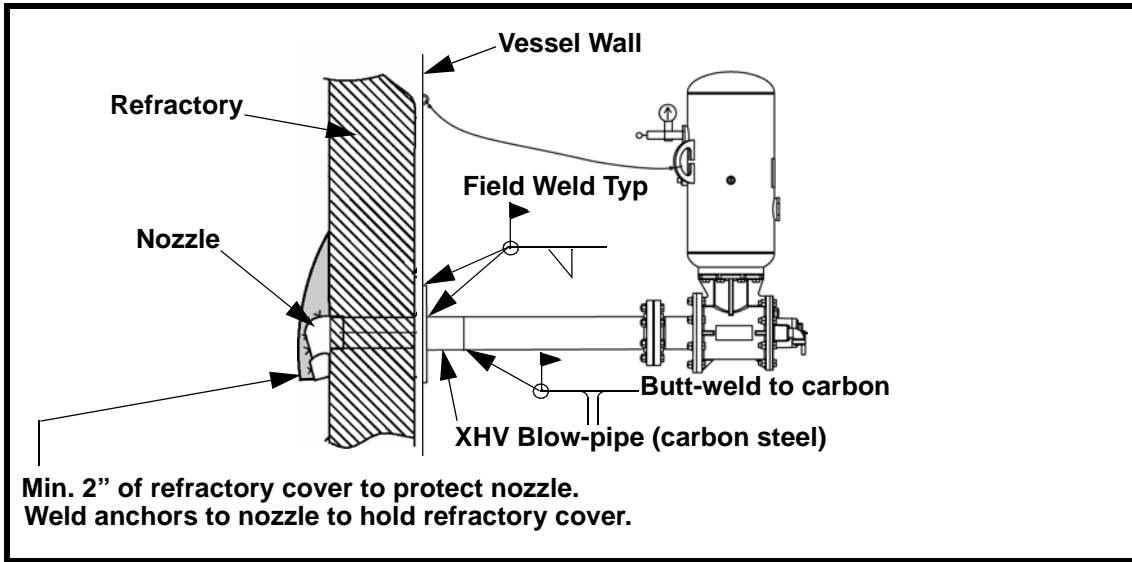

Figure 9. Installing 90-Degree Stainless Steel Nozzle for High-Temperature Applications

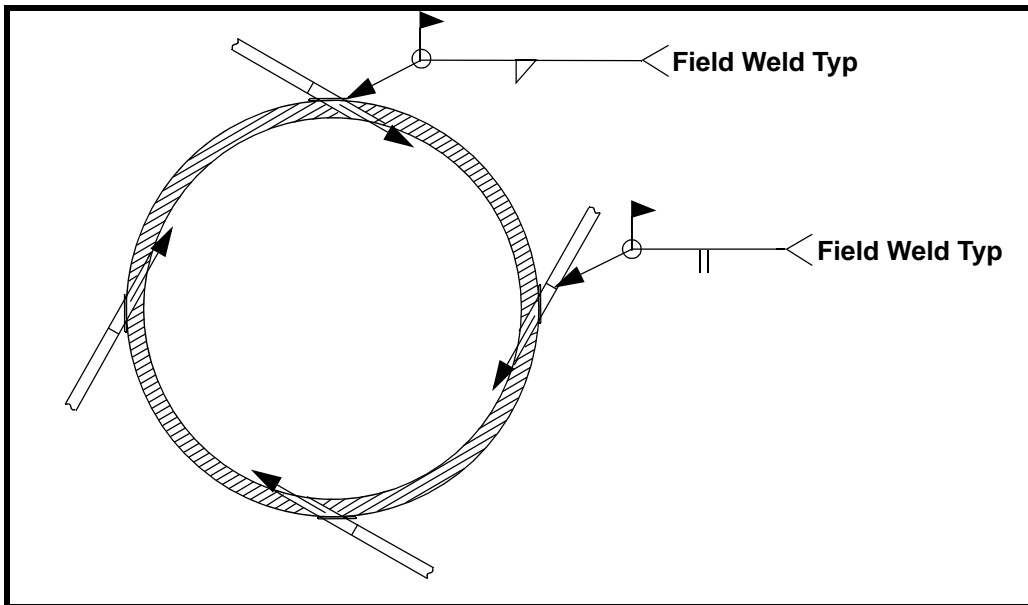

Figure 10. Cyclone with High-Temperature Blow Pipes

Connecting air cannon to mounting plate

1. One flange will be connected to blow pipe and other will be connected to air cannon's discharge flange weldment.
 - a. For threaded end pipe, screw pipe flange onto pipe completely. If necessary, tack weld connection to prevent from becoming loose. DO NOT weld threaded connection completely.
 - b. For plain end pipe, place slip-on flange over end of pipe and fillet weld completely.
2. Place a gasket between the flanges and assemble using screws, nuts and compression washers.

Installing restraining cable

WARNING

Always install restraining cable to secure air cannon to storage vessel. Without restraining cable, air cannon could fall and cause injury.

Do not use restraining cable to mount air cannon to storage vessel wall. Purpose of restraining cable is to keep air cannon from falling should it come loose from vessel wall, not as primary means of securing air cannon to wall.

IMPORTANT

Do not use angle iron or support ring to secure air cannon rigidly to storage vessel. If restrained too rigidly, tank cannot flex and air cannon can fail.

1. Weld D-ring (A, Figure 11) onto storage vessel (B) with 1/4-in. (6-mm) field weld.

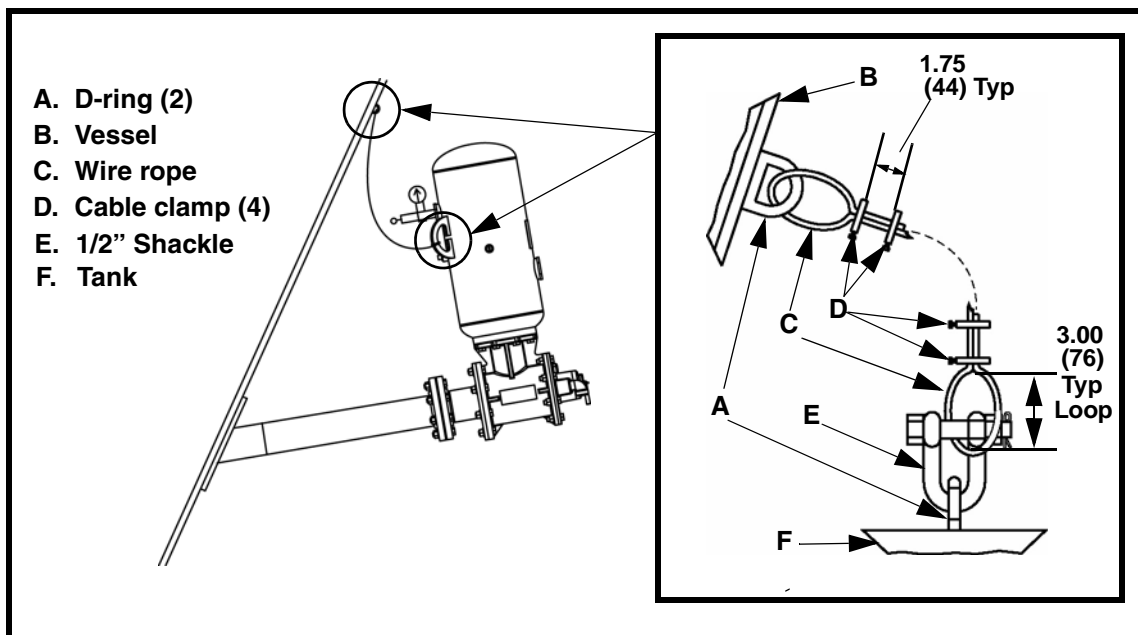

Figure 11. Installing Restraining Cable

2. Insert wire rope (C) through D-ring on storage vessel, making a 3-in. (76-mm) loop. If wire rope supplied with air cannon is not long enough, loop and clamp it to an additional cable and attach additional cable to air cannon.
3. Clamp wire rope with one cable clamp (D) as close to loop as possible. Place another cable clamp 1-3/4 in. (44 mm) from first clamp.
4. Leave at least 1 in. (25 mm) of wire rope on dead end.
5. Gradually tighten nuts alternately and evenly to 15 ft-lbs. Leave 2 to 3 in. (51 to 76 mm) slack in wire rope.
6. Use the U-bolt to connect the restraining cable to one of the D-rings on tank. Tighten U-bolt pin with a wrench and insert cotter pin through the hole. Separate ends of cotter pin to ensure U-bolt pin cannot back out.

Connecting air supply to air cannon

IMPORTANT

Read entire section before beginning work.

▲ CAUTION

When pressure in storage vessel is 4 psi (0.28 bar) or more, apply equal or greater pressure to the air cannon inlet. Absence of inlet pressure will allow material in storage vessel to enter the air cannon and contaminate the valve body and tank.

IMPORTANT

To prevent leaking, apply pipe sealant to all fittings. Air cannon will not pressurize if leaks are present.

1. Apply pipe sealant to all fittings.

▲ WARNING

MSHA/OSHA requires the use of an ASME-approved relief valve and an air pressure gauge (see “References”).

2. Remove dust cap from tank inspection port(s) and install pressure relief valve and air pressure gauge. The pressure relief valve and air pressure gauge can be installed in the same port using the ½” tee provided with the plumbing kit or air pressure gauge kit. Make sure all ports are tightly plugged.
3. Remove recessed hex-head screw from the valve’s fill port. See Figure 12 or 13.

▲ WARNING

Make sure exhaust ports on MARTIN® TORNADO Exhaust Valve elbows are pointed downward so that dirt cannot enter and exhaust is not directed at personnel. Do not plug or reduce the diameter of the exhaust ports.

IMPORTANT

Electric solenoid valves distributed by Martin Engineering are recommended. Substitute valves may not work as effectively.

NOTE

Additional control valves such as manually-actuated valves, explosion-proof valves, and box-enclosed manifolds are also available from Martin Engineering. Contact your local representative for detailed information if you are installing one of these options. Solenoid ports are (1) inlet, (2) outlet, and (3) exhaust.

4. Connect the 3-way electric solenoid valve.
 - a. If using a normally-opened solenoid valve, connect the 3-way electric solenoid valve outlet port (2) to MARTIN[®] TORNADO Exhaust Valve fill port. See Figure 12.
 - b. If using a normally-closed solenoid valve, connect the 3-way electric solenoid valve outlet port (2) to MARTIN[®] TORNADO Exhaust Valve control port. See Figure 13.
5. Connect air filter/regulator to the 3-way electrical solenoid valve inlet port with desired length of ½” pipe. Look at arrow on side of filter/regulator to make sure flow is correct.

IMPORTANT

OSHA/MSHA requires installation of a lockout ball valve (see “References”).

6. Connect lockout ball valve to air filter/regulator with desired length of ½” pipe. Look at arrow on side of ball valve to make sure flow is correct.
7. Connect lockout ball valve to compressed air source with desired length of ½” pipe. Additional lockout ball valves can be placed in fill and control lines as desired.

IMPORTANT

For electrical solenoid valve installations, design and wire electrical solenoid controls according to NEC Handbook. Electrical push buttons, timers, and programmable controllers are available through Martin Engineering.

8. For electrical solenoid valve installations, if using electrical solenoid controller, install according to instructions provided with controller.

⚠ WARNING

Do not exceed 125 psi (8.62 bar) maximum working pressure or the pressure relief valve will open. Minimum recommended pressure for most applications is 80 psi (5.52 bar), but lower pressures can be used. Make sure air supply is filtered and regulated.

NOTE

Pressure relief valves of up to 150 psi are available from Martin Engineering. Consult the Maximum Allowable Working Pressure (MAWP) on the tank's name plate before substituting a different pressure relief valve. Never use a pressure relief valve with a set pressure that is higher than the MAWP of the tank.

⚠ WARNING

The pressure relief valve may relieve at any point between 90% and 100% of set pressure. Exceeding the MAWP of the tank can cause it to rupture.

9. Anchor all pipes and wires to prohibit movement.

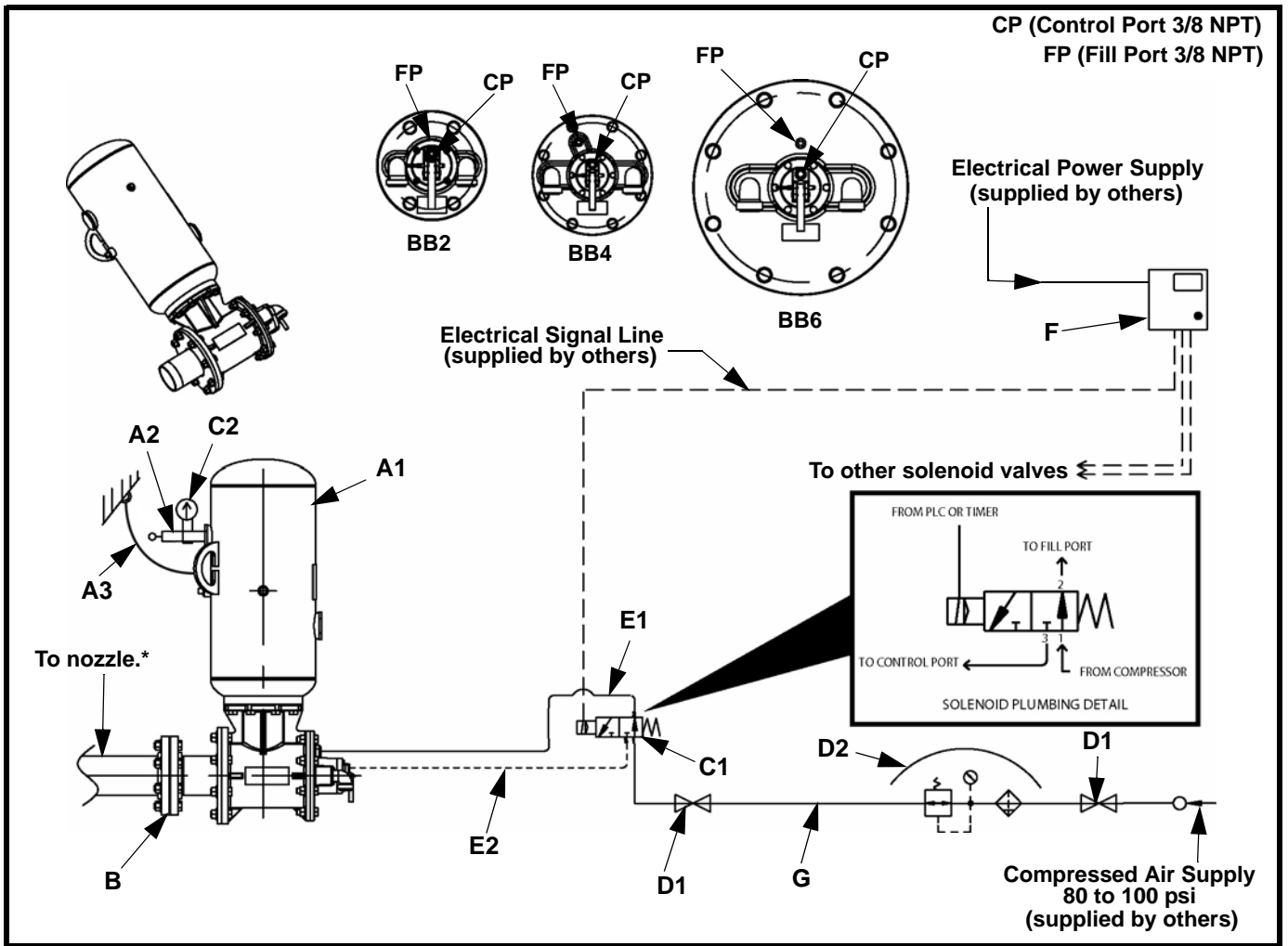

Figure 12. Plumbing Detail for Normally-Opened Solenoid Valve

Item	Description	Assembly and Kit Part Numbers**
A1	BIG BLASTER® XHV Air Cannon with MARTIN® TORNADO Exhaust Valve	See Appendix A
A2	Safety Relief Valve	
A3	Safety Cable	
B	NPT Flange Assembly	See Appendix A
C1	3-Way 2-Position Solenoid Valve (normally opened)	37885-110
C2	Air Pressure Gauge	37892
D1	Lockout Valve	
D2	Filter Regulator Unit	37890-XX
E1	Air Fill Hose	
E2	Air Control Hose	36756 or by others
F	Controller/PLC	
G	Air Supply Pipe	103008 or by others

* Contact MARTIN ENGINEERING for recommendation.

** Contact MARTIN ENGINEERING for breakdown of parts contained in assemblies and kits.

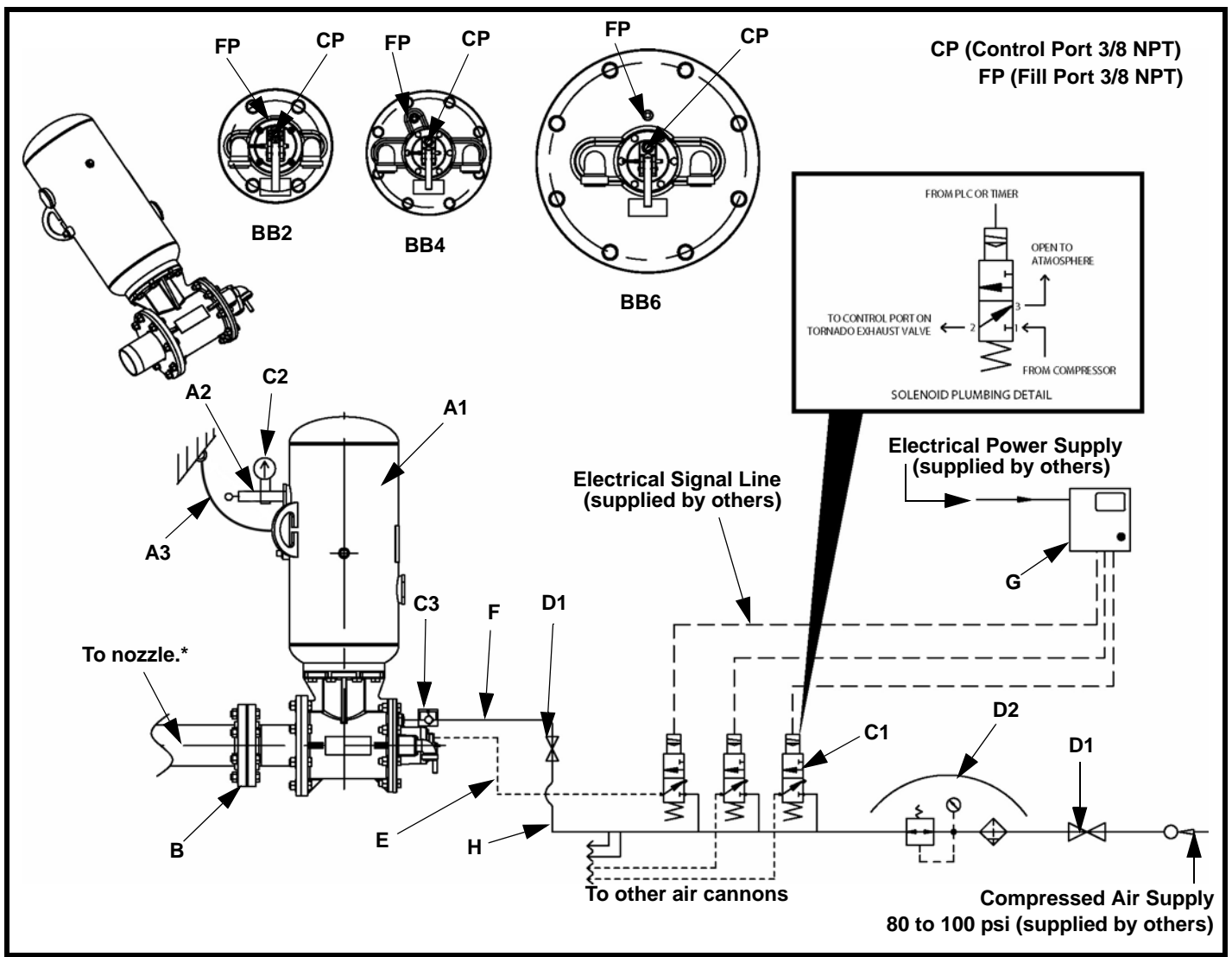

Figure 13. Plumbing Detail for Normally-Closed Solenoid Valve

Item	Description	Assembly & Kit Part Numbers**
A1	BIG BLASTER® XHV Air Cannon with MARTIN® TORNADO Exhaust Valve	See Appendix A
A2	Safety Relief Valve	
A3	Safety Cable	
B	NPT Flange Assembly	See Appendix A
C1	3-Way 2-Position Solenoid Valve (normally closed)	37886-110
C2	Air Pressure Gauge	
C3	Flow Control Valve	
D1	Lockout Valve	37890-XX
D2	Filter Regulator Unit	
E	Air Control Kit	33739
F	Air Supply Hose	37452
G	Controller/PLC	36756 or by others
H	Air Supply Pipe	103008 or by others

* Contact MARTIN ENGINEERING for Recommendation.

** Contact MARTIN ENGINEERING for breakdown of parts contained in assemblies and kits.

After Installing Air Cannon

IMPORTANT

Read entire section before beginning work.

1. Thoroughly wipe storage vessel wall clean next to vessel door/port. Place Air Blast Warning Label, P/N 31913, on vessel wall visible to anyone opening door/port. If more than one door or port exists on storage vessel, request additional labels from Martin Engineering or representative. Attach Lockout Valve Warning Tag, P/N 35146, to lockout valve with cable tie (supplied).
2. Purge air lines.

IMPORTANT

Charge each air cannon individually during initial start-up to avoid significant pressure loss.

Relief valve is preset to open at 125 psi (8.62 bar).

⚠ WARNING

Do not exceed 125 psi (8.62 bar) maximum working pressure or pressure relief valve will open. Minimum recommended pressure for most applications is 80 psi (5.52 bar) but lower pressures can be used. Make sure air supply is filtered and regulated.

NOTE

Pressure relief valves of up to 150 psi are available from Martin Engineering. Consult the Maximum Allowable Working Pressure (MAWP) on tank's name plate before substituting a different pressure relief valve. Never use a pressure relief valve with a set pressure that is higher than the MAWP of the tank.

⚠ WARNING

Pressure relief valve may relieve at any point between 90% and 100% of set pressure. Exceeding MAWP can cause tank to rupture.

3. Supply 80 to 125 psi (5.52 to 8.62 bar) filtered and regulated air to system.
4. If air cannon does not charge, see “Troubleshooting.”
5. Check system for air leaks. If leaking, see “Troubleshooting.”

NOTE

When air cannon blasts, a small amount of air will release from solenoid valve and exhaust valve ports.

⚠ DANGER

Do not open door/port or enter storage vessel when cannons are charged and operational. Flying debris from cannons' blast can kill you.

If air cannons are installed on open pit or on structure with no top, make sure area is clear before firing cannons. Flying debris from cannons' blast can kill you.

⚠ WARNING

Air cannons are loud when firing. Use ear protection to avoid impairment or loss of hearing.

6. Blast air cannon as follows: for air cannons with electrical solenoid valves and external electrical controls, activate electrical solenoid valve by external control (electrical push button, timer, etc.) or by pushing button on electrical solenoid valve. (If wired correctly, this should send signal to solenoid valve closing inlet to outlet and opening outlet to exhaust.)
7. Blast air cannon five times to ensure proper operation. Allow tank to fill after each blast.
8. If air cannon blasts properly, continue to operate air cannon as needed. If problems occur, see "Troubleshooting."
9. Keep air cannon charged with air at all times so unit is always ready for use and so material cannot flow into air cannon.

IMPORTANT

Read entire section before beginning work.

⚠ WARNING

Turn off and lock out/tag out air supply and energy source before blasting air cannon to prevent air cannon from refilling.

⚠ WARNING

Do not open door/port or enter storage vessel before turning off compressed air source, locking out controls, purging line pressure, and venting air completely from tank.

Turn off and lock out/tag out energy source according to ANSI standards (see “References”).

Every month

1. Inspect all connections from air supply to tank for leaks and deterioration. If connections are leaking, seal all fittings with pipe sealant and tighten. Replace any deteriorating connections. Make sure hoses do not flex more than 1/4 inch (6 mm).
2. Make sure all pipes and wires are anchored to prohibit movement. Secure as needed.
3. Inspect BIG BLASTER[®] XHV Air Cannon with MARTIN[®] TORNADO Exhaust Valve assembly, electrical solenoid valve, lockout ball valve, and air filter/regulator for proper operation. If not operating correctly, replace.
4. Inspect air gauge for correct operation; make sure lens is clean and visible.
5. Inspect safety relief valve: pull ring to bleed off a small amount of compressed air and make sure diaphragm closes back to an air-tight seal.
6. Inspect safety cable (restraining cable); make sure clamp connections are secure and there is no excessive corrosion or frayed cable.
7. Wipe all warning labels clean. If labels are not readable, contact Martin Engineering or representative for replacements.

*Every year or
50,000 firings*

1. Blast air cannon to remove air from tank, then pull ring on relief valve to make sure air stored in cannon has been released.
2. Perform monthly maintenance. See “Every month.”
3. After all air is released, remove drain plug. Allow all moisture to drain from tank.
4. After all moisture is removed, apply pipe sealant to drain plug. Install drain plug on tank.



Do not weld tank. Paint in tank will melt and welding will violate ASME code. If tank is damaged or leaking, do not use air cannon until tank is replaced or repaired by Martin Engineering.

5. Inspect air cannon mounting area for rust and loose screws, welds, and bolts. Replace, tighten, or weld as necessary.
6. Inspect tank, valve body, piston, and discharge nozzle for damage. Replace or return to Martin Engineering for repair as necessary.
7. Inspect restraining cable for wear. Replace if worn.
8. On units with electrical controls, inspect wires and connections. Repair or replace wires to NEC Handbook standards as necessary.

Troubleshooting

If air cannon will not charge or discharge, find possible cause(s) in appropriate chart below and follow steps in “Solution” column. If after doing so you are still experiencing problems, contact Martin Engineering or representative.

Problem: Air Cannon Will Not Charge	
Cause	Solution
Compressor source.	Make sure compressor is on and air line has pressure.
Ball valves open.	Check that ball valves are fully open to each cannon.
Filter/Regulator.	Factory-set at zero. Rotate clockwise to increase. Check plumbing air flow direction (indicated with an arrow).
Solenoid plumbing.	Check connections. Port 1 = inlet; Port 2 = outlet; Port 3 = exhaust.
Tank plugs missing.	Check to see whether any NPT ports on tank have been left open.
Fill port connection on air cannon.	Check that air supply is connected to “fill port.”

Problem: Air Cannon Will Not Discharge	
Cause	Solution
Solenoid plumbing.	Make sure plumbing is correct. Check for leaks. Check plumbing direction.
Solenoid electrical.	Make sure wiring is connected. Check that voltage is correct. Check for signal.
Tank pressure.	Check air gauge.
Control line is not correct.	Check that control line is connected correctly to air cannon and solenoid.
Air cannon exhaust ports.	Check street elbows. The [two] 1-inch street elbows CAN NOT be plugged or reduced down.
Blocked discharge—cannon makes “sputtering” sound when discharging; air gauge drops slowly or does not go all the way to zero.	Remove blockage.
Control line has a leak or blockage.	Check that air line is not too long (over 200 ft.).
Operating pressure is low.	Check that operating pressure is at 80–100 psi.
Control signal too short.	Make sure that solenoid stays on long enough for correct operation (1 second).
Air gauge not working correctly.	Be sure that air gauge drops to “0” psi in less than ½ second.

Part Numbers

This section provides product names and corresponding part numbers for BIG BLASTER® XHV Air Cannons with MARTIN® TORNADO Exhaust Valves and related equipment. Please reference part numbers when ordering parts. Part numbers for accessory equipment not listed here are available from Martin Engineering or representative.

***BIG BLASTER®
XHV Air Cannon
with MARTIN®
TORNADO
Exhaust Valve***

BIG BLASTER® XHV Air Cannon with MARTIN® TORNADO Exhaust Valve Assembly:

BB2-08-12 XHV TORNADO: 37864-0812

BB2-08-20 XHV TORNADO: 37864-0820

BB4-12-28 XHV TORNADO: 37798-1228

BB4-20-30 XHV TORNADO: 37798-2030

BB4-24-48 XHV TORNADO: 37798-2448

BB4-30-60 XHV TORNADO: 37798-3060

BB6-20-30 XHV TORNADO: 37853-2030

BB6-24-48 XHV TORNADO: 37853-2448

BB6-30-60 XHV TORNADO: 37853-3060

***Air Cannon
Repair Parts***

Pressure Relief Valve: P/N 21680

Air Pressure Gauge: P/N 34842

Safety Cable Kit: P/N 32271

MARTIN® TORNADO Exhaust Valve Rebuild Kit:

BB2: 38137-2

BB4: 38137-4

BB6: 38137-6

MARTIN® TORNADO Exhaust Valve Cap Lever Replacement Kit:

BB2: 38136-2

BB4 and BB6: 38136

Contact Martin Engineering for information on other repair parts.

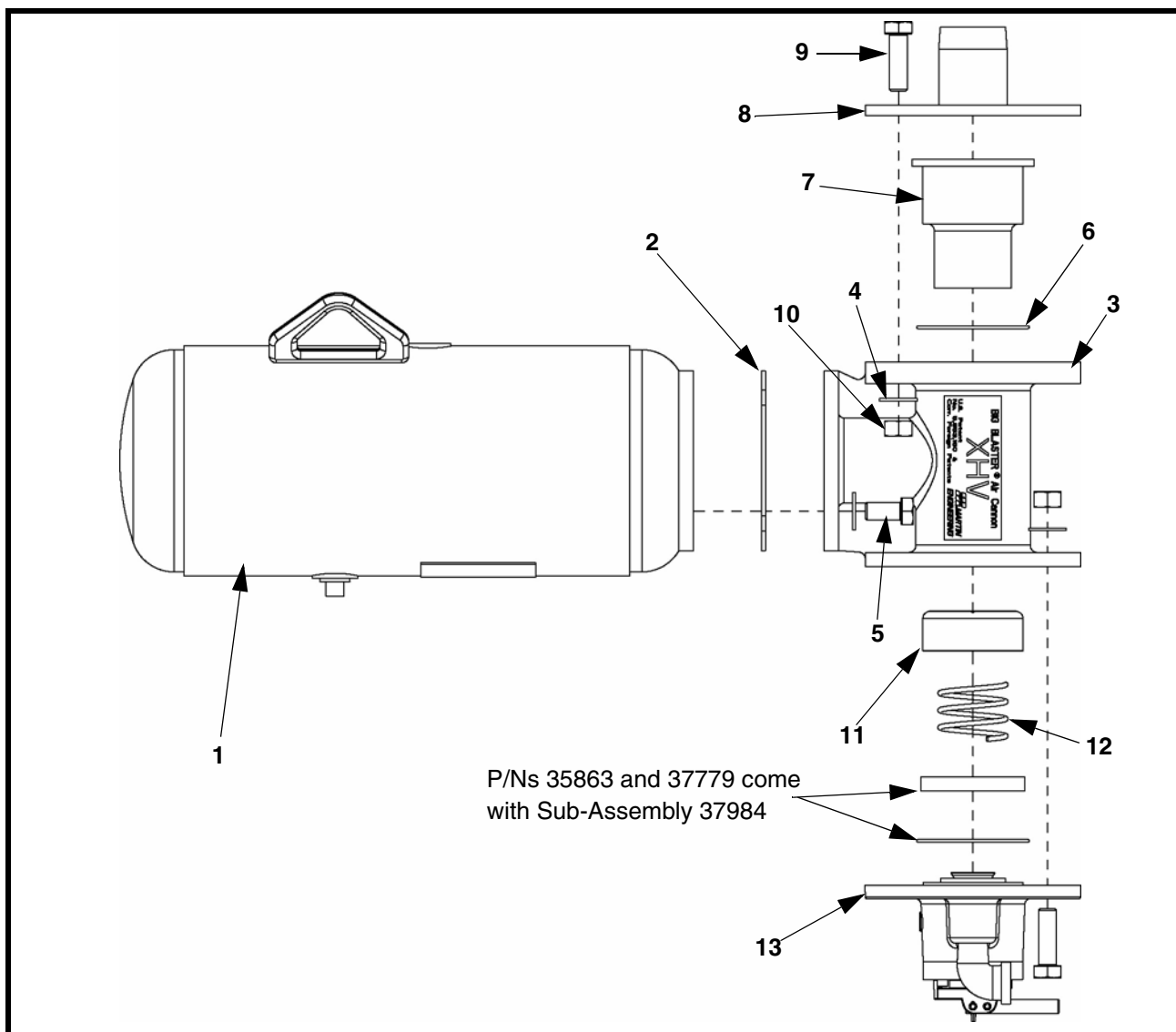

Figure 14. BIG BLASTER® XHV Air Cannon with MARTIN® TORNADO 2'' Exhaust Valve Assembly, P/N 37864-XXXX*

Item	Description	Part No.	Qty
1	Tank Weldment	21858 or 23128	1
2	Tank Gasket for 2.00 XHV	35872	1
3	Valve Body Assembly	35853-B	1
4	Washer Compression 5/8	11752	14
5	Screw HHC 5/8-11NC x 1-1/4 ZP	15798	4
6	O-ring 3-3/4 ID Viton	35863	1
7	Piston Seat for 2.00 XHV	35861	1
8	Discharge Weldment for 2.00 XHV	35860	1
9	Screw HHC 5/8-11NC x 2 ZP	18831	10
10	Nut Hex 5/8-11NC ZP	11772	10
11	Piston with Urethane for 2.00 Air Cannon	37961	1
12	Compression Spring	35865	1
13	MARTIN® TORNADO 2.00 Valve Cap Sub-Assembly	37984	1

*First XX indicates tank diameter; Last XX indicates tank length. Available sizes: 0812 and 0820.

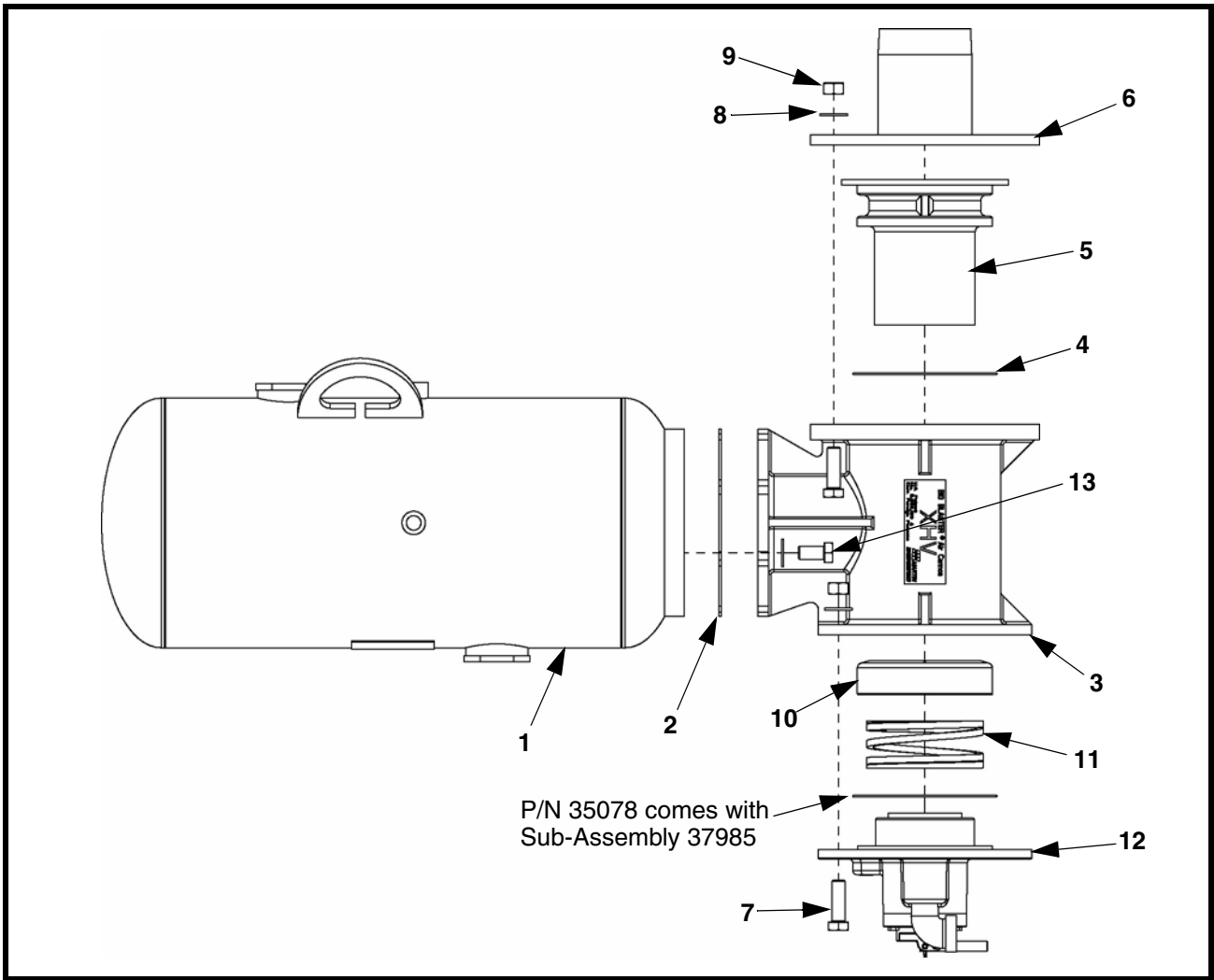

Figure 15. BIG BLASTER® XHV Air Cannon with MARTIN® TORNADO 4” Exhaust Valve Assembly, P/N 37798-XXXX*

Item	Description	Part No.	Qty
1	Tank Weldment	31027-XXXX*	1
2	Tank Gasket 4.00 XHV	35080	1
3	Valve Body Assembly	35076	1
4	O-ring #166 6.737 ID x 0.094 CS	35078	1
5	Piston Seat	35075	1
6	Discharge Flange Weldment	35081	1
7	Screw HHC 5/8-11NC ZP	18831	16
8	Washer Compression 5/8	11752	24
9	Nut Hex 5/8-11NC ZP	11772	16
10	Piston with Urethane for 4.00 Air Cannon	37962	1
11	Compression Spring	35077	1
12	MARTIN® Tornado 4.00 Valve Cap Sub-Assembly	37985	1
13	Screw HHC 5/8-11NC x 1-1/4 ZP	15798	8

*First XX indicates tank diameter; Last XX indicates tank length. Available sizes: 1228, 2030, 2448, and 3060.

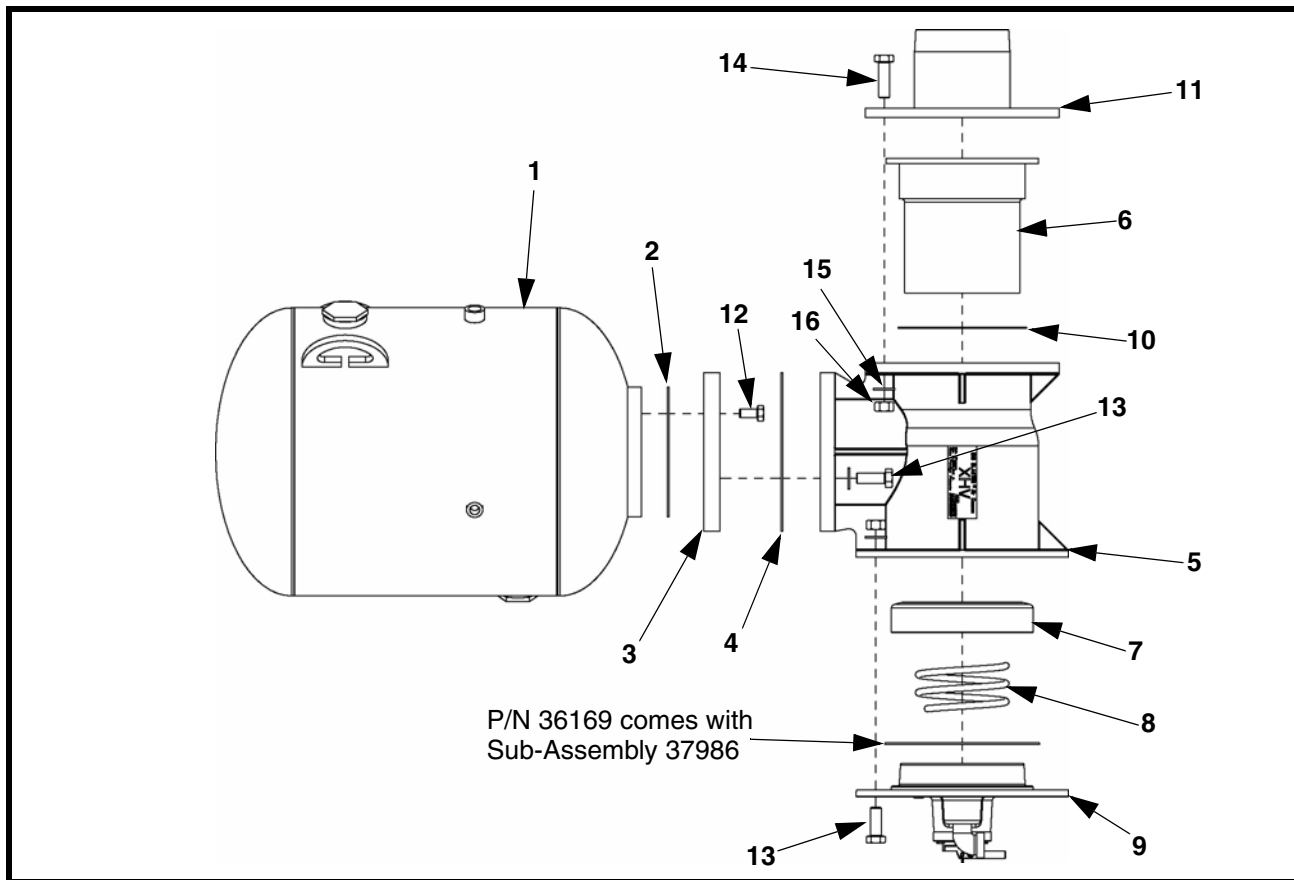

Figure 16. BIG BLASTER® XHV Air Cannon with MARTIN® TORNADO 6” Exhaust Valve Assembly, P/N 37853-XXXX*

Item	Description	Part No.	Qty
1	Tank Weldment	31027-XXXX*	1
2	Tank Gasket	36263	1
3	Flange Transition	36261	1
4	Transition Gasket	36173	1
5	Valve Body Assembly	36114	1
6	Piston Seat	36113	1
7	Piston with Urethane for 6.00 Air Cannon	37963	1
8	Compression Spring	36167	1
9	MARTIN® TORNADO 6.00 Valve Cap Sub-Assembly	37986	1
10	O-ring #174 8.737 ID x 0.103 CS	36262	1
11	Discharge Flange Weldment	36170	1
12	Screw HHC 5/8-11NC 1-1/4 ZP	15798	8
13	Screw HHC 3/4-10NC 2 ZP	19135	16
14	Screw HHC 3/4-10NC 2-1/2 ZP	17770	8
15	Washer Compression	11754	24
16	Nut Hex 3/4-10NC ZP	11773	16

*First XX indicates tank diameter; Last XX indicates tank length. Available sizes: 2030, 2448, and 3060.

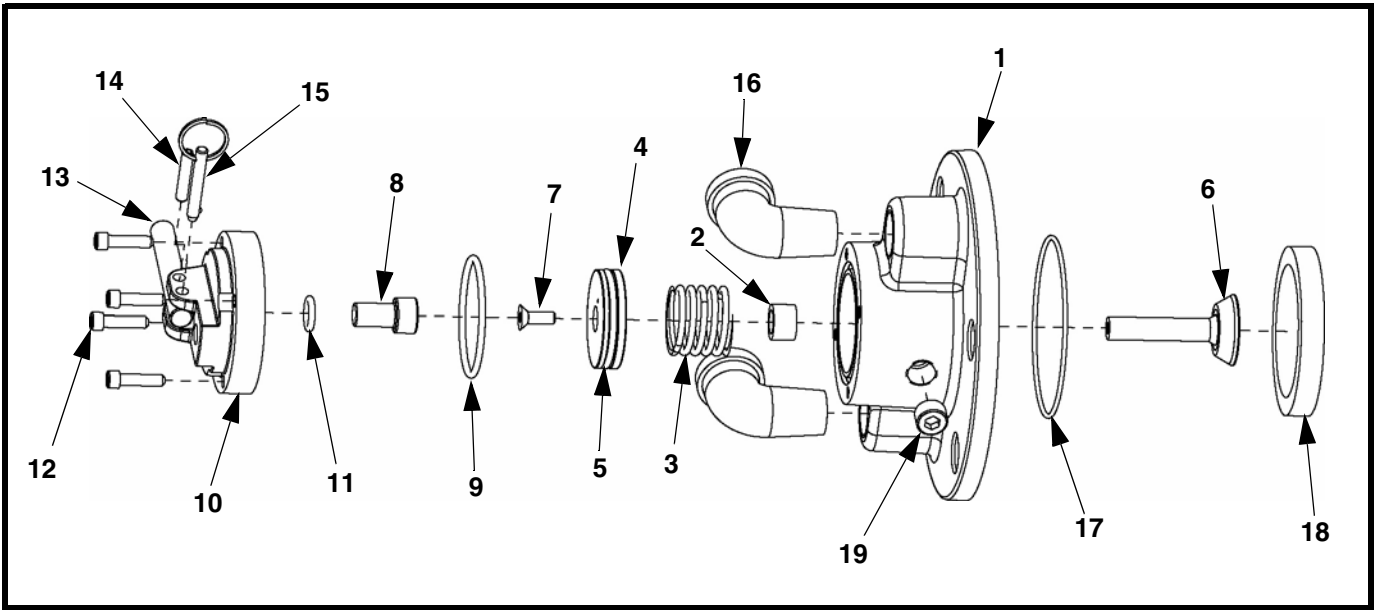

Figure 17. MARTIN® TORNADO 2" Exhaust Valve Assembly, P/N 37984

Item	Description	Part No.	Qty	Kit
1	Valve Body Cap	37847	1	
2	Sleeve Bearing	37287	1	I
3	Spring Compression	37860	1	I
4	Piston 2.00	37858	1	I
5	O-ring #225 1.86 ID x 0.139	M435	1	I
6	MARTIN® TORNADO 2.00 Air Inlet Valve Assembly	37857-U	1	I
7	Screw FSHC 1/4-20NC x 0.75	30453	1	I
8	Plunger 4.00 Pos QEV Valve	37791	1	II
9	O-ring #229 0.484 ID x 0.139 CS	37859	1	I & II
10	Top Cap 2.00 Pos QEV Valve	37861	1	II
11	O-ring #206 0.484 ID x 0.139 CS	37795	1	II
12	Screw SHC 1/4-20NC x 1	12627	4	
13	Handle 4.00 Pos QEV Cap	37792	1	II
14	Pin Slotted Spring	32403	1	II
15	Pin Quick Release	37796	1	II
16	Street Elbow 3/4 NPT Galvanized	13052	2	
17	O-ring 3-3/4 ID Viton	35863	1	I
18	2.00 XHV Piston Bumper	37779	1	
19	Plug 3/8 NPT Hex Socket	37987	1	

I = Parts included in MARTIN® TORNADO 2" Exhaust Valve Actuator Assembly Rebuild Kit, P/N 38137-2 (Includes P/N 16345, Woodruff Key)

II = Parts included in MARTIN® TORNADO Exhaust Valve Cap Lever Replacement Kit, P/N 38136-2

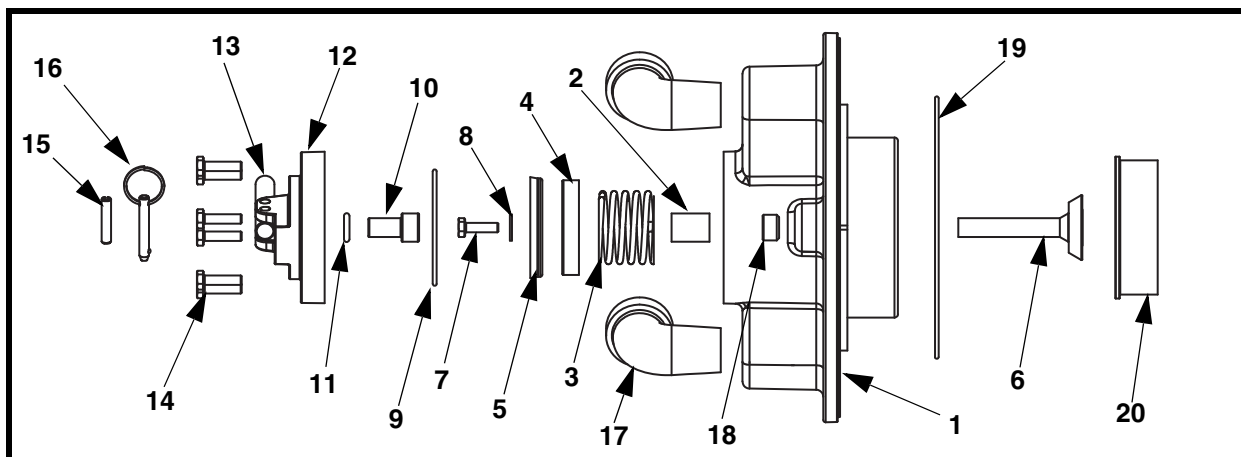

Figure 18. MARTIN® BB4 TORNADO Exhaust Valve, P/N 37985

Item	Description	Part Number	Qty	Kit
1	Valve Body Cap	37775	1	
2	Bearing Sleeve	37287-1	1	I
3	Compression Spring 1.937 OD	34671	1	I
4	Piston	38635	1	I
5	Lip Seal Puck	38634	1	I
6	Air Inlet Valve	37790-B	1	I
7	Screw HHC 1/4-20NC x 7/8	11891	1	I
8	Washer Compression 1/4	11521	1	I
9	O-Ring #150 2.862 ID x .103 CS	37794	1	I & II
10	Plunger	37791	1	II
11	O-Ring #206 .484 ID x .139 CS	37795	1	II
12	Top Cap	37776	1	II
13	Handle	37792	1	II
14	Screw SHC 1/4-20NC x 1	12699	6	
15	Slotted Spring Pin 1/4 x 1-1/4 SS	32403	1	II
16	Quick Release Pin 1/4 x 1.63 ZP	37796	1	II
17	Street Elbow 1 NPT Galv	36124	2	
18	Hex Socket Plug 3/8 NPT	37987	1	
19	O-Ring #166 6.737 ID x .094 CS	35078	1	I
20	Urethane Bumper	37793	1	I

I = Parts included in MARTIN® TORNADO 4" Exhaust Valve Actuator Assembly Rebuild Kit, P/N 38137-4 (Includes P/N 16345, Woodruff Key)

II = Parts included in MARTIN® TORNADO Exhaust Valve Cap Lever Replacement Kit, P/N 38136

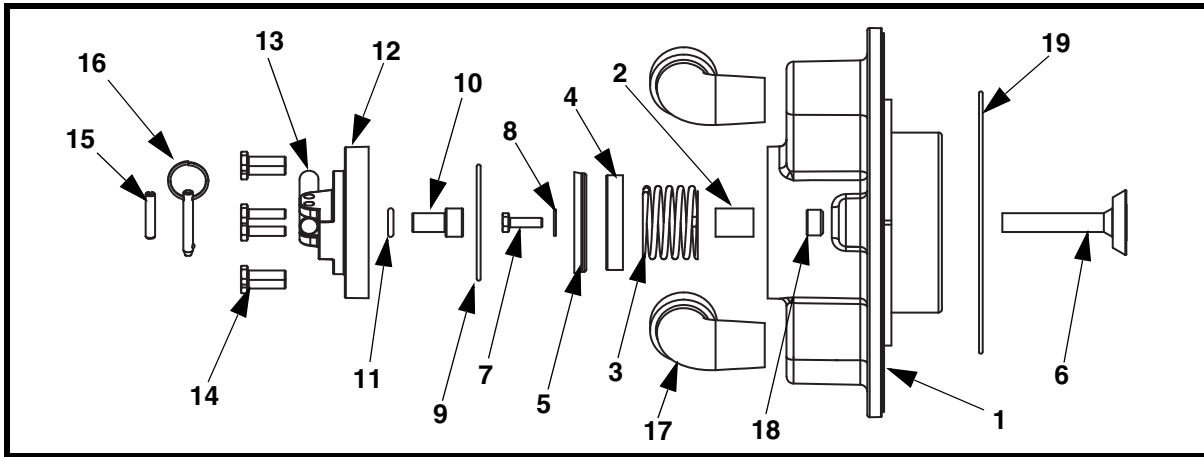

Figure 19. MARTIN[®] BB6 TORNADO Exhaust Valve, P/N 37986

Item	Description	Part Number	Qty	Kit
1	Valve Body Cap	37848	1	
2	Bearing Sleeve	37287-1	1	I
3	Compression Spring 1.937 OD	34671	1	I
4	Piston	38635	1	I
5	Lip Seal Puck	38634	1	I
6	Air Inlet Valve	37790-B	1	I
7	Screw HHC 1/4-20NC x 7/8	11891	1	I
8	Washer Compression 1/4	11521	1	I
9	O-Ring #150 2.862 ID x .103 CS	37794	1	I & II
10	Plunger	37791	1	II
11	O-Ring #206 .484 ID x .139 CS	37795	1	II
12	Top Cap	37776	1	II
13	Handle	37792	1	II
14	Screw SHC 1/4-20NC x 1	12699	6	
15	Slotted Spring Pin 1/4 x 1-1/4 SS	32403	1	II
16	Quick Release Pin 1/4 x 1.63 ZP	37796	1	II
17	Street Elbow 1 NPT Galv	36124	2	
18	Hex Socket Plug 3/8 NPT	37987	1	
19	O-Ring #275 10.484 ID x .139 CS	36169	1	I

I = Parts included in MARTIN[®] TORNADO 6" Exhaust Valve Actuator Assembly Rebuild Kit, P/N 38137-6 (Includes P/N 16345, Woodruff Key)

II = Parts included in MARTIN[®] TORNADO Exhaust Valve Cap Lever Replacement Kit, P/N 38136



Figure 20. Air Cannon Warning Label, P/N 33439

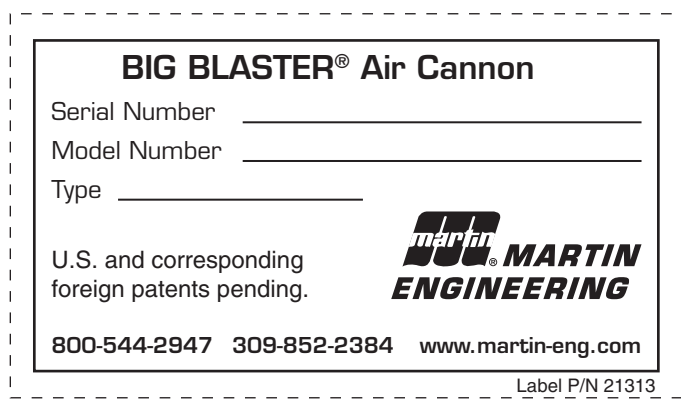

Figure 21. BIG BLASTER® Serial/Model Number Label, P/N 21313



Figure 22. Air Blast Warning Label, P/N 31913

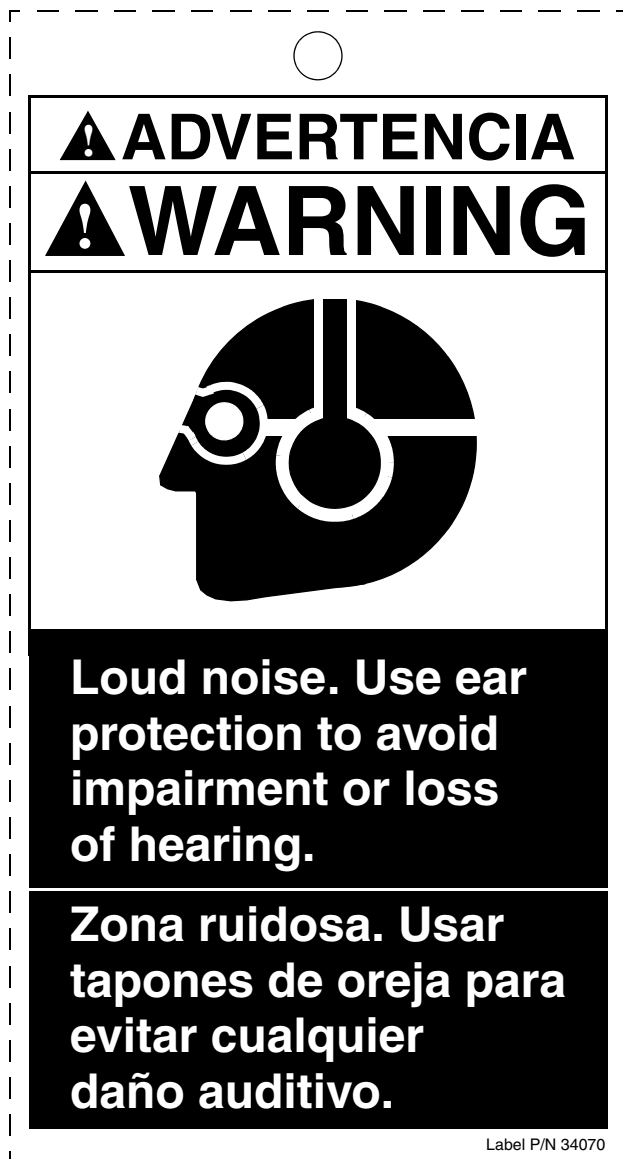
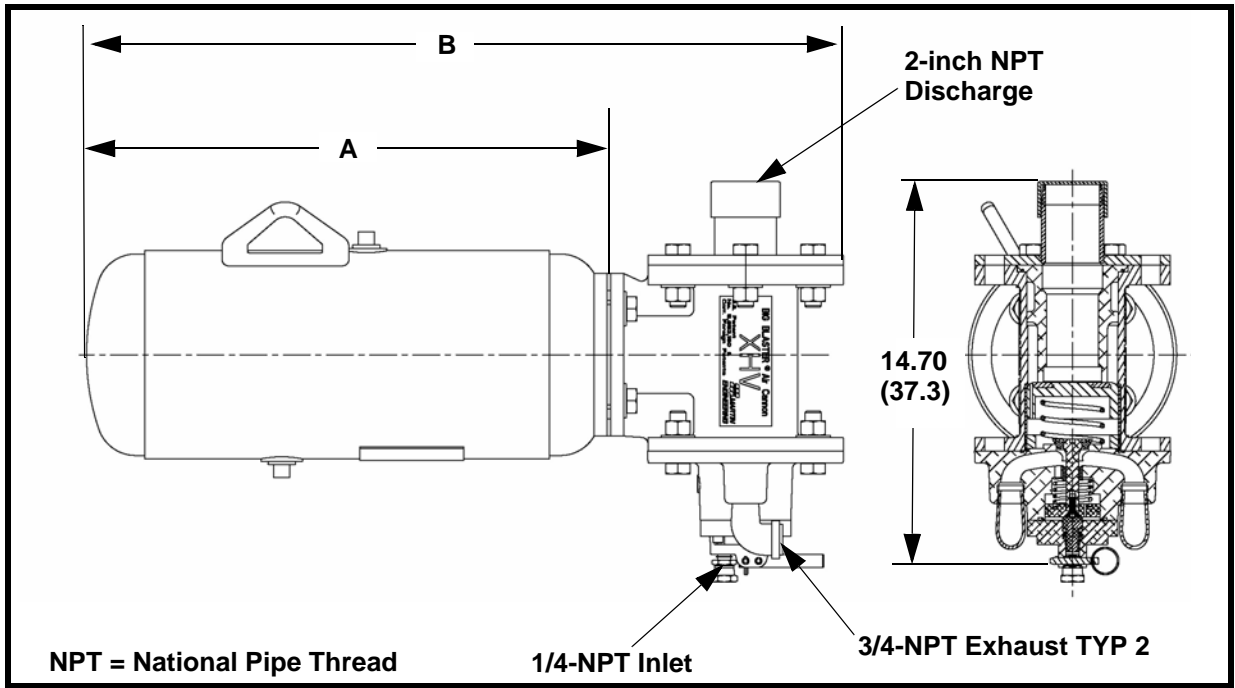

Figure 23. Loud Noise Warning Tag, P/N 34070

Notes

Appendix A
BIG BLASTER® XHV Air Cannon with
MARTIN® TORNADO Exhaust Valve
Specifications and Performance Data

BIG BLASTER® XHV Air Cannon with MARTIN® TORNADO 2" Exhaust Valve Data



Dimensions inches (mm)				
Model	Assembly P/N	Dim. A	Dim. B	Ship Weight lb. (kg)
BB2-08-12	37864-0812	12 (305)	21.07 (535)	50 (23)
BB2-08-20	37864-0820	20 (508)	29.07 (738)	57 (26)

Air Volume in ft ³ (Liters) Free Air		
Air Pressure psi	0812 Tank ft ³ (L)	0820 Tank ft ³ (L)
0	0.3 (8)	0.5 (15)
40	1.1 (31)	1.9 (55)
50	1.3 (37)	2.3 (65)
60	1.5 (43)	2.6 (75)
70	1.7 (49)	3.0 (85)
75	1.8 (51)	3.2 (90)
80	1.9 (54)	3.3 (95)
85	2.0 (57)	3.5 (100)
90	2.1 (60)	3.7 (105)
95	2.2 (63)	3.9 (110)
100	2.3 (66)	4.1 (115)
110	2.5 (72)	4.4 (125)
120	2.7 (77)	4.8 (135)

BIG BLASTER® XHV Air Cannon with MARTIN® TORNADO 4" Exhaust Valve Data

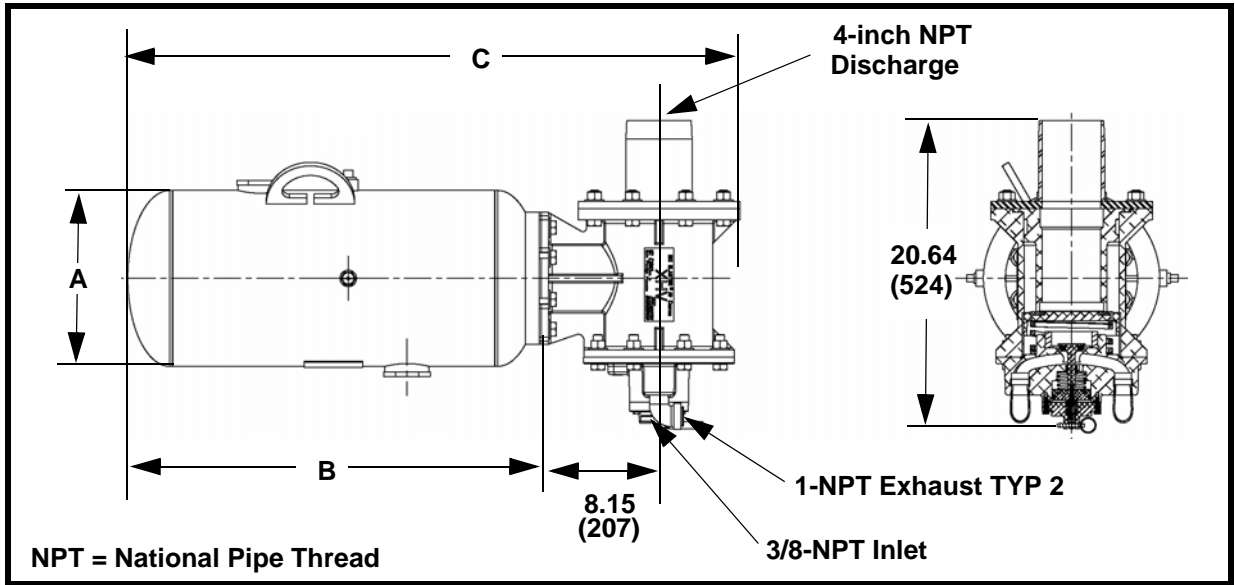

Dimensions inches (mm)					
Model	Assembly P/N	Dim. A	Dim. B	Dim. C	Ship Weight lb. (kg)
BB4-12-28	37798-1228	12 (305)	28.00 (711)	41.65 (1058)	113 (51.25)
BB4-20-30	37798-2030	20 (508)	29.59 (752)	43.24 (1098)	151 (68.51)
BB4-24-48	37798-2448	24 (610)	48.00 (1219)	61.65 (1566)	211 (95.7)
BB4-30-60	37798-3060	30 (762)	60.00 (1524)	73.65 (1871)	312 (141.5)

Air Volume in ft ³ (Liters) Free Air				
Air Pressure psi	1228 ft ³ (L)	2030 ft ³ (L)	2448 ft ³ (L)	3060 ft ³ (L)
0	1.7 (47)	4.8 (135)	11.2 (319)	22.0 (622)
40	6.2 (174)	17.7 (501)	41.9 (1185)	81.8 (2315)
50	7.3 (206)	20.9 (593)	49.5 (1402)	96.7 (2738)
60	8.4 (238)	24.2 (684)	57.2 (1619)	111.6 (3161)
70	9.5 (270)	27.4 (776)	64.8 (1835)	126.6 (3585)
75	10.1 (286)	29.0 (822)	68.6 (2052)	141.5 (4008)
85	11.2 (317)	32.2 (913)	76.3 (2160)	149.0 (4219)
90	11.8 (333)	33.9 (959)	80.1 (2269)	156.5 (4431)
95	12.3 (349)	35.5 (1005)	83.9 (2377)	164.0 (4643)
100	12.9 (365)	37.1 (1051)	87.8 (2485)	171.4 (4854)
110	14.0 (397)	40.3 (1142)	95.4 (2702)	186.4 (5277)
120	15.1 (429)	43.6 (1234)	103.1 (2919)	201.3 (5701)

BIG BLASTER® XHV Air Cannon with MARTIN® TORNADO 6” Exhaust Valve Data

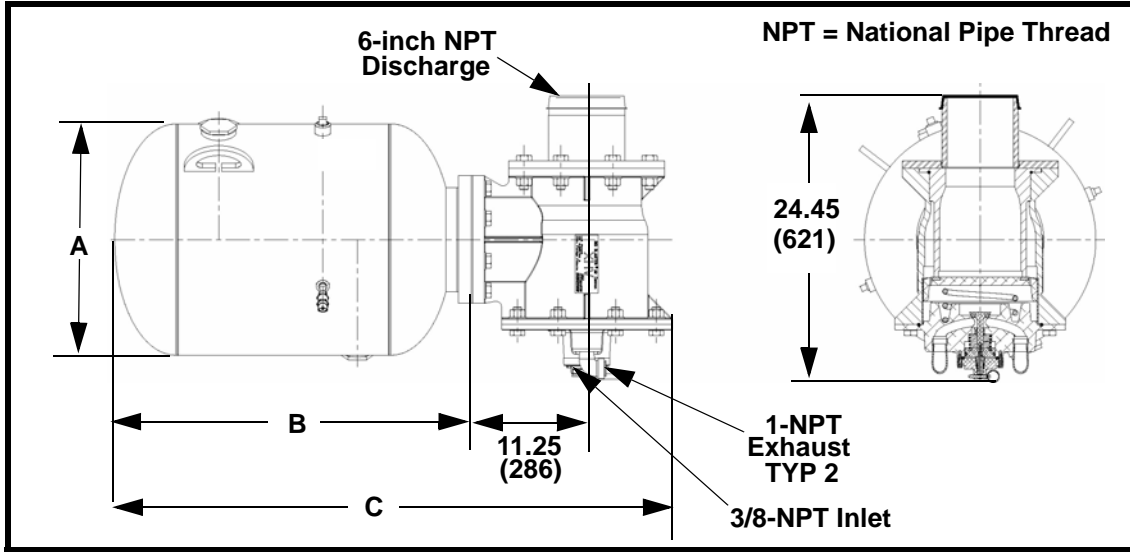

Dimensions inches (mm)					
Model	Assembly P/N	Dim. A	Dim. B	Dim. C	Ship Weight lb. (kg)
BB6-20-30	37798-2030	20 (508)	29.59 (752)	47.59 (1209)	240 (109)
BB6-24-48	37798-2448	24 (610)	48.00 (1219)	66.00 (1676)	301 (136)
BB4-30-60	37798-3060	30 (762)	60.00 (1524)	78.00 (1981)	402 (182)

Air Volume in ft ³ (Liters) Free Air			
Air Pressure psi	2030 ft ³ (L)	2448 ft ³ (L)	3060 ft ³ (L)
0	4.8 (135)	11.2 (319)	22.0 (622)
40	17.7 (501)	41.9 (1185)	81.8 (2315)
50	20.9 (593)	49.5 (1402)	96.7 (2738)
60	24.2 (684)	57.2 (1619)	111.6 (3161)
70	27.4 (776)	64.8 (1835)	126.6 (3585)
75	29.0 (822)	68.6 (2052)	141.5 (4008)
85	32.2 (913)	76.3 (2160)	149.0 (4219)
90	33.9 (959)	80.1 (2269)	156.5 (4431)
95	35.5 (1005)	83.9 (2377)	164.0 (4643)
100	37.1 (1051)	87.8 (2485)	171.4 (4854)
110	40.3 (1142)	95.4 (2702)	186.4 (5277)
120	43.6 (1234)	103.1 (2919)	201.3 (5701)

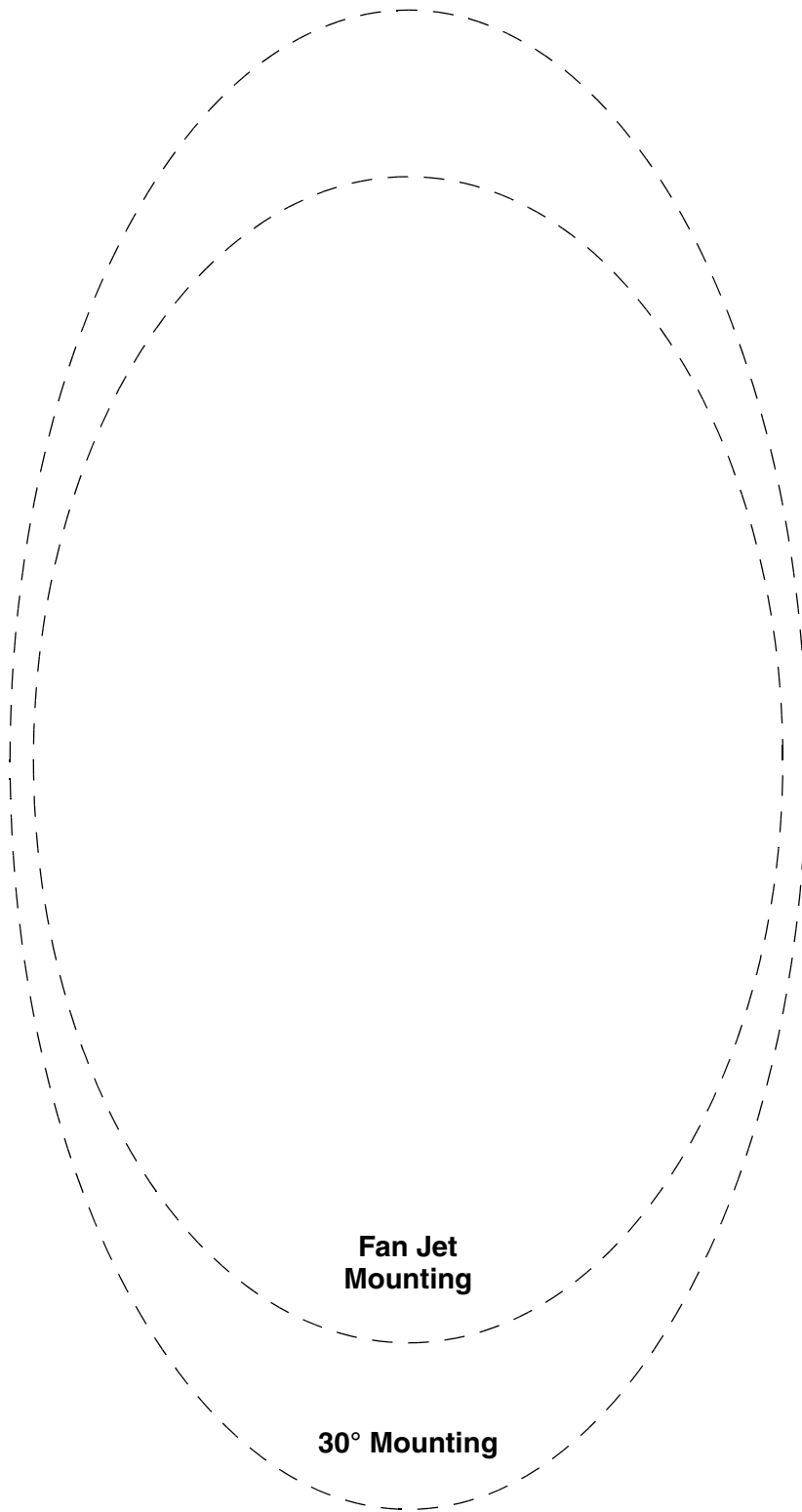

**Mount 30-degree mounting plates vertically.
Mount fan jet mounting plates either vertically or horizontally.
Contact Martin Engineering for more information.**

Any product, process, or technology described here may be the subject of intellectual property rights reserved by Martin Engineering Company. Trademarks or service marks designated with the ® symbol are registered with the U.S. Patent and Trademark Office and may be proprietary in one or more countries or regions. Other trademarks and service marks belonging to Martin Engineering Company in the United States and/or other countries or regions may be designated with the “TM” and “SM” symbols. Brands, trademarks, and names of other parties, who may or may not be affiliated with, connected to, or endorsed by Martin Engineering Company, are identified wherever possible. Additional information regarding Martin Engineering Company’s intellectual property can be obtained at www.martin-eng.com/trademarks.

Problem Solved™



Martin Engineering USA

One Martin Place
Neponset, IL 61345-9766 USA
800 544 2947 or 309 852 2384
Fax 800 814 1553
www.martin-eng.com

Subject to change without prior notice.

Quality Management System Certified by DNV - ISO 9001

**QUALITY MANAGEMENT SYSTEM
CERTIFIED BY DNV**

==== ISO 9001:2008 ====