

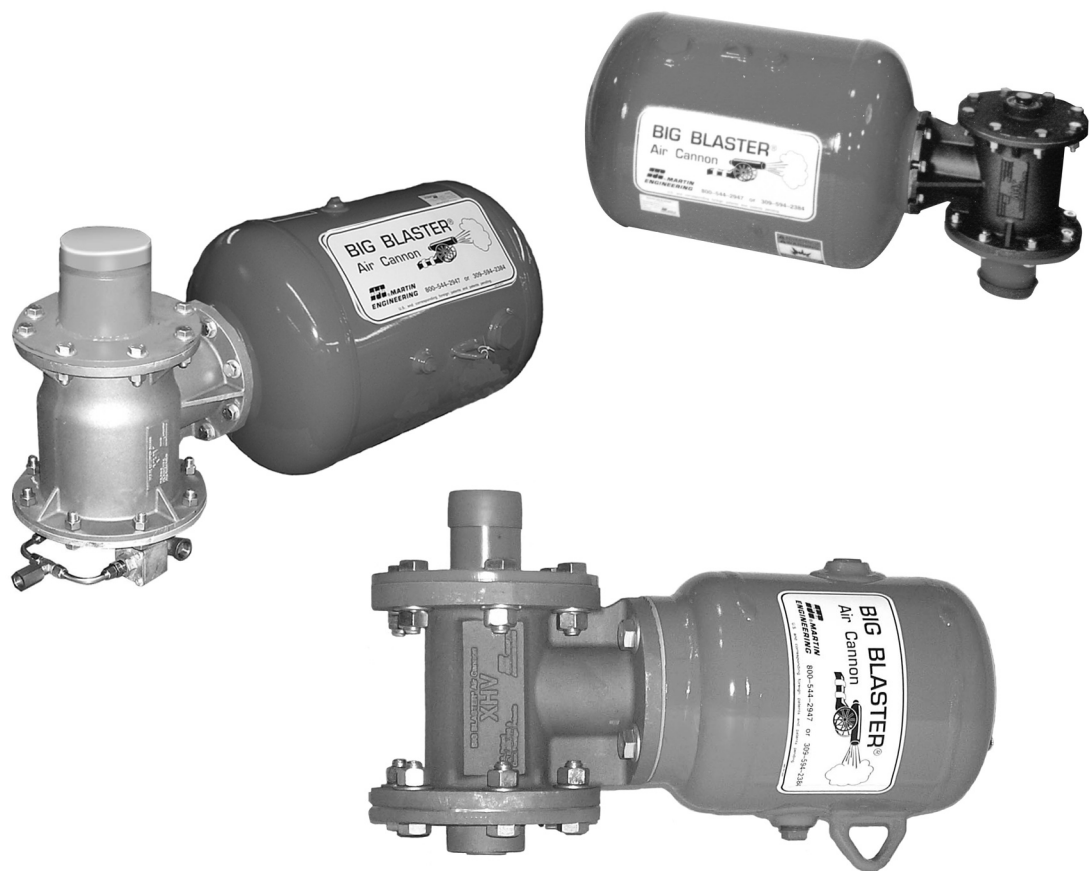

# ***BIG BLASTER® XHV Air Cannon***

[Go to BIG BLASTER® XHV Air Cannon web page](#)



***Operator's Manual  
M3404***

# Important

MARTIN ENGINEERING HEREBY DISCLAIMS ANY LIABILITY FOR: DAMAGE DUE TO CONTAMINATION OF THE MATERIAL; USER'S FAILURE TO INSPECT, MAINTAIN AND TAKE REASONABLE CARE OF THE EQUIPMENT; INJURIES OR DAMAGE RESULTING FROM USE OR APPLICATION OF THIS PRODUCT CONTRARY TO INSTRUCTIONS AND SPECIFICATIONS CONTAINED HEREIN. MARTIN ENGINEERING'S LIABILITY SHALL BE LIMITED TO REPAIR OR REPLACEMENT OF EQUIPMENT SHOWN TO BE DEFECTIVE.

Observe all safety rules given herein along with owner and Government standards and regulations. Know and understand lockout/tagout procedures as defined by American National Standards Institute (ANSI) z244.1-1982, *American National Standard for Personnel Protection - Lockout/Tagout of Energy Sources - Minimum Safety Requirements* and Occupational Safety and Health Administration (OSHA) Federal Register, Part IV, 29 CFR Part 1910, *Control of Hazardous Energy Source (Lockout/Tagout); Final Rule*.

The following symbols may be used in this manual:



**Danger:** Immediate hazards that will result in severe personal injury or death.



**Warning:** Hazards or unsafe practices that could result in personal injury.



**Caution:** Hazards or unsafe practices that could result in product or property damages.



**Important:** Instructions that must be followed to ensure proper installation/operation of equipment.



**Note:** General statements to assist the reader.

# Table of Contents

---

<b>Section</b>	<b>Page</b>
List of Figures .....	ii
Introduction .....	1
General .....	1
Operation .....	1
Air cannon materials .....	1
Model and serial numbers .....	2
Specifications .....	3
Required accessories .....	3
References .....	4
Safety .....	4
Materials required .....	4
Before Installing Air Cannon .....	5
Installing Air Cannon .....	7
Installing mounting plate .....	7
Connecting air cannon to mounting plate .....	11
Installing restraining cable .....	12
Connecting air supply to air cannon .....	13
Installing manual valves and electrical solenoid valves .....	13
Installing solenoid enclosures .....	16
After Installing Air Cannon .....	19
Maintenance .....	21
Every month .....	21
Every year or 50,000 firings .....	22
Troubleshooting .....	23
Repair .....	25
Disassembly .....	25
Inspection .....	26
Assembly .....	26
Part Numbers .....	28
BIG BLASTER <sup>®</sup> XHV Air Cannons .....	28
Mounting accessories .....	28
Air Control components/kits .....	29
Miscellaneous .....	29
Appendix A. BIG BLASTER <sup>®</sup> XHV Air Cannon Specifications .....	A-1
Appendix B. BIG BLASTER <sup>®</sup> XHV Air Cannon Labels .....	B-1

## List of Figures

---

<b>Figure</b>	<b>Title</b>	<b>Page</b>
1	Restricted Material .....	1
2	Air Cannon Charging and Discharging .....	2
3	Serial and Model Number Plate .....	2
4	Air Cannon Accessories .....	4
5	Standard Mounting Plate .....	7
6	30° Mounting Plate .....	8
7	Fan Jet Mounting Plate .....	8
8	Mounting Nozzles/Pipes (High Temp. Applications) .....	9
9	Installing Mounting Plate (High Temp. Applications) .....	9
10	Riser Duct with Fan Jet Blow Nozzles (High Temp. Applications) .....	10
11	Cyclone with High-Temperature Blow Pipes .....	11
12	Installing Restraining Cable .....	12
13	Manual Valve Piping .....	14
14	Electrical Solenoid Valve Piping .....	14
15	Solenoid Enclosure Piping .....	17
16a	BIG BLASTER® XHV 6” Air Cannon Assembly, P/N 36260-XXXX .....	30
16b	BIG BLASTER® XHV 6” Air Cannon Assembly Parts List .....	31
17a	BIG BLASTER® XHV 4” Air Cannon Assembly, P/N 35132-XXXX .....	32
17b	BIG BLASTER® XHV 4” Air Cannon Assembly Parts List .....	33
18a	BIG BLASTER® XHV 2” Air Cannon Assembly, P/N 35859-XXXX .....	34
18b	BIG BLASTER® XHV 2” Air Cannon Assembly Parts List .....	35

## List of Tables

---

<b>Table</b>	<b>Title</b>	<b>Page</b>
I	BIG BLASTER® XHV 6” Air Cannon Tank Weldment Part Numbers .....	31
II	BIG BLASTER® XHV 4” Air Cannon Part Numbers .....	33
III	BIG BLASTER® XHV 2” Air Cannon Tank Weldment Part Numbers .....	35

# Introduction

## General

The BIG BLASTER<sup>®</sup> XHV Air Cannons are pneumatic, bulk material-moving systems that quickly release compressed air into a storage vessel to restore flow to material that is clinging (A), bridging (B), rat-holing (C), or arching (D) (see Figure 1). This manual provides instructions for installing cannons on steel structures only. For installations on other structures, call Martin Engineering or a representative.

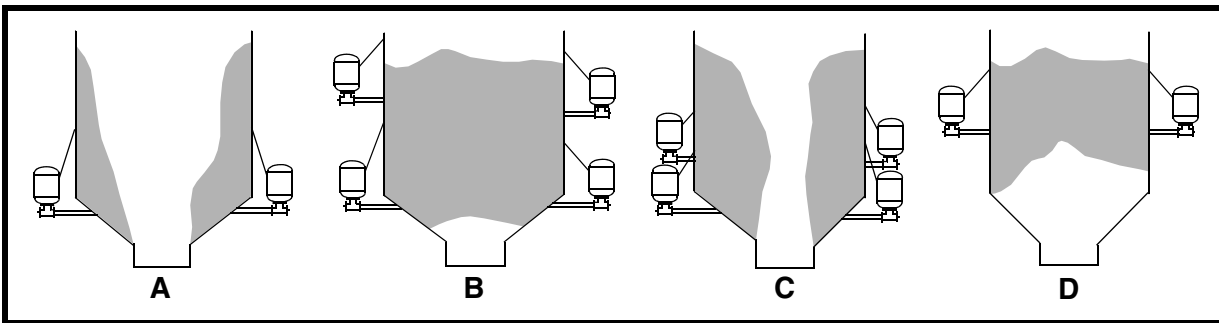

Figure 1. Restricted Material

## Operation

The MARTIN<sup>®</sup> XHV Air Cannon System consists of one or more air cannons mounted on a storage vessel. The air cannon charges when the tank is filled with plant compressed air or nitrogen between 40 psi (2.76 bar) and 120 psi (8.27 bar) (A, Figure 2) that is controlled by a 3-way normally open solenoid valve. Air fed through the valve body-mounted quick exhaust valve (QEV) passes through the piston and into the tank (B). When tank pressure equals line pressure, airflow is static and the cannon is ready to discharge (C). By activating the solenoid valve, the air supply is shut off and the air line between the QEV and solenoid is emptied. This allows the QEV to quickly release the pressure holding the piston. The piston is instantly forced back by the pressure stored in the tank which then exits through the discharge pipe, releasing the energized air pressure stored in the tank. This blast of air is directed through the discharge pipe and into the storage vessel (D).

## Air cannon materials

The air cannon tank is manufactured to American Society of Mechanical Engineers (ASME) Code Rules, Section VIII, Division 1. It is National Board registered, and is pressure vessel quality (PVQ). After the tank is welded, paint is applied inside the tank to prevent rust and corrosion. **Never weld tank.** Welding will melt paint and violate ASME coding.

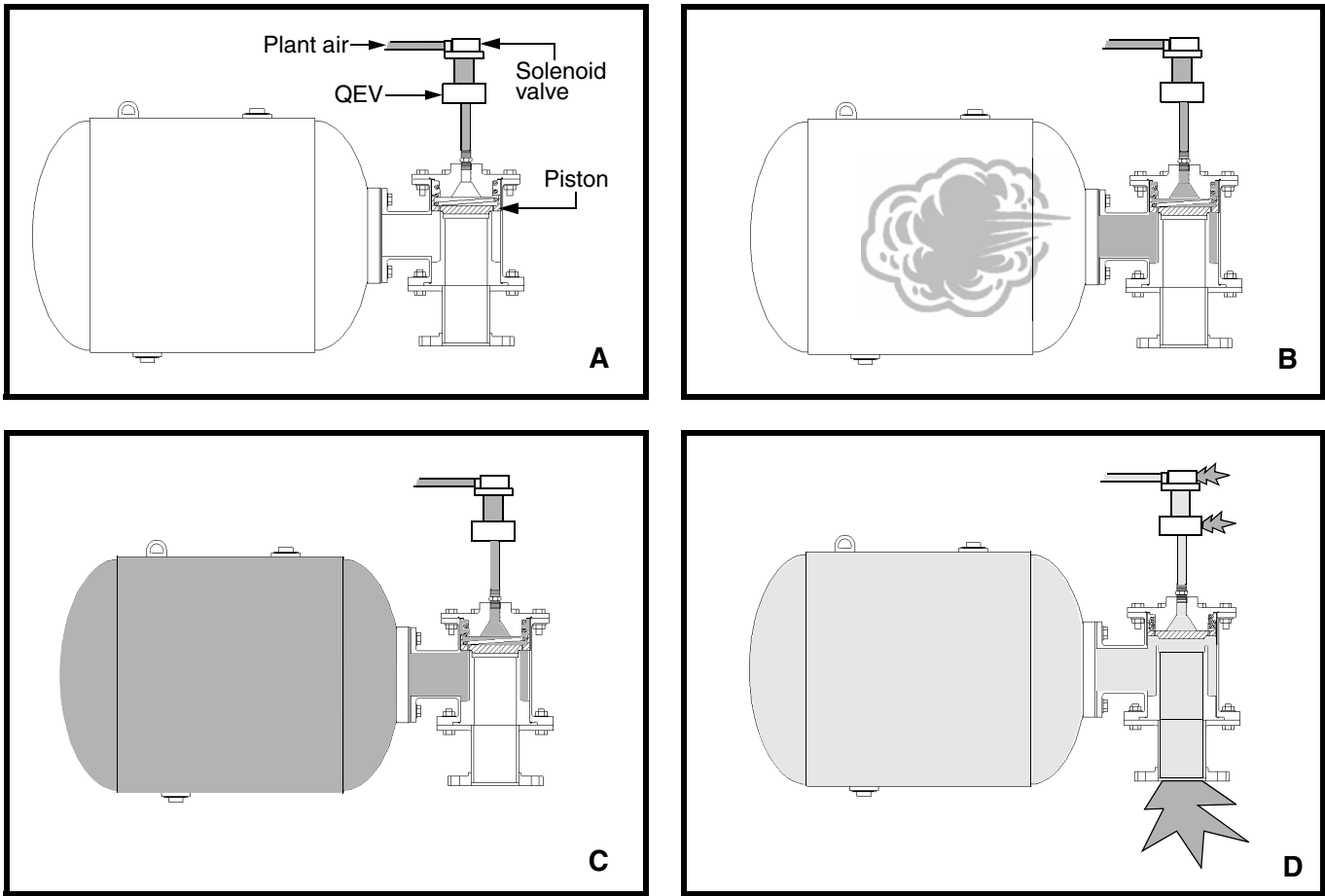

Figure 2. Air Cannon Charging and Discharging

**Model and serial numbers**

Each MARTIN® XHV Air Cannon’s serial and model number is shown on a plate attached to the tank (see Figure 3). Serial and model numbers must be referenced when ordering parts from Martin Engineering or representative, and on all correspondence.

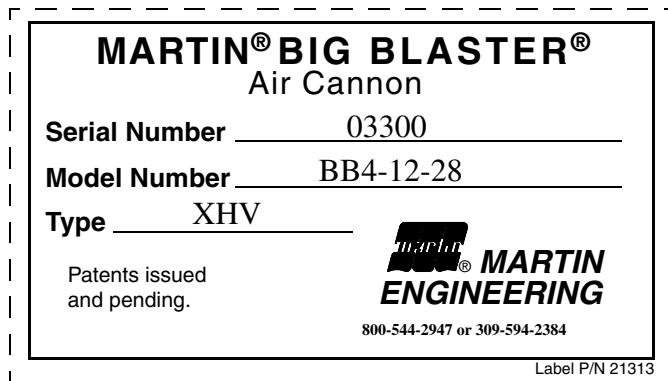

Figure 3. Serial and Model Number Plate

Each model number is made up of “BB” followed by three numbers separated by dashes. The first number indicates discharge pipe diameter, the second number indicates tank diameter, and the third number indicates tank length (all in inches). For example, model BB4-12-28 has a nominal discharge diameter of 4 in. (102 mm), a tank diameter of 12 in. (305 mm), and a tank length of 28 in. (711 mm).

### ***Specifications***

Nine different MARTIN® XHV Air Cannon models are available. Each model is listed below. The volume of air held in the tank increases with pressure.

<b>Air Cannon Model</b>	<b>Part Number</b>
BB2-8-12	35859-0812
BB2-8-20	35859-0820
BB4-12-28	35132-1228
BB4-20-30	35132-2030
BB4-24-48	35132-2448
BB4-30-60	35132-3060
BB6-20-30	36260-2030
BB6-24-48	36260-2448
BB6-30-60	36260-3060

Air cannon dimensions, tank volume, fill times, and discharge times are provided in Appendix A.

### ***Required accessories***

This manual includes instructions for installing accessories required for XHV Air Cannons to be fully operational (see Figure 4). The following accessories can be ordered from Martin Engineering and shipped separately from air cannons (see “Part Numbers”):

- Quick exhaust valve (A).
- Air control components: manual valve (B) or electrical solenoid valve (C), air filter (D), air regulator (E), air lubricator (F), lockout ball valve (G), and check valve (H).

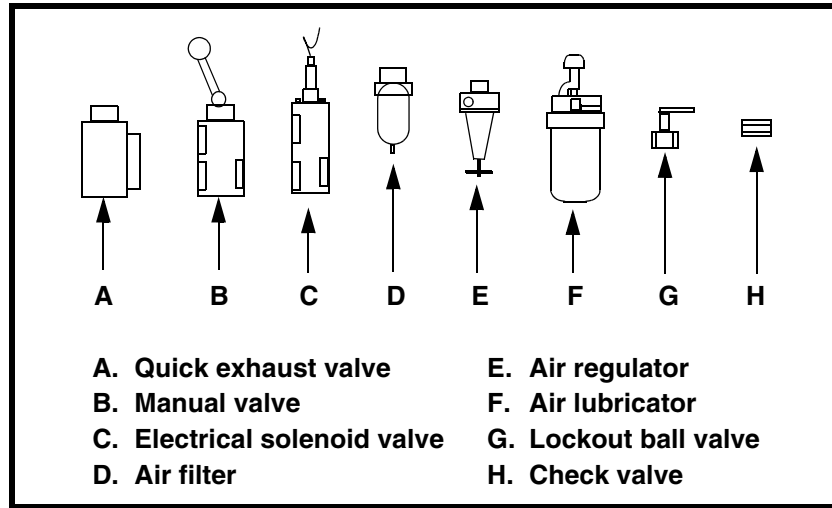

**Figure 4. Air Cannon Accessories**

## References

The following documents are referenced in this manual:

- American National Standards Institute (ANSI) z244.1-1982, *American National Standard for Personnel Protection - Lockout/Tagout of Energy Sources - Minimum Safety Requirements*, American National Standards Institute, Inc., 1430 Broadway, New York, NY 10018.
- Federal Register, Volume 54, Number 169, Part IV, 29 CFR Part 1910, *Control of Hazardous Energy Source (Lockout/Tagout); Final Rule*, Department of Labor, Occupational Safety and Health Administration (OSHA), 32nd Floor, Room 3244, 230 South Dearborn Street, Chicago, IL 60604.
- *The National Electrical Code (NEC) Handbook*, National Fire Protection Association, 1 Batterymarch Park, P.O. Box 9101, Quincy MA 02269-9101.
- ICS 1-1988, *General Standards for Industrial Control and Systems*, and 250-1985, *Enclosures for Electrical Equipment (1000 Volts Maximum)*, National Electrical Manufacturers Association (NEMA), 2101 L Street N.W., Washington, D.C. 20037.
- *Section VIII, Rules for Construction of Pressure Vessels, Division 1*, American Society of Mechanical Engineers, United Engineering Center, 345 East 47th Street, New York, NY 10017.

## Safety

All safety rules defined in the above documents, and all owner/employer safety rules, must be strictly followed when installing and servicing this equipment.

## Materials required

Materials other than standard hand tools that are required to complete tasks are listed where applicable.

# Before Installing Air Cannon

---

## **IMPORTANT**

**The delivery service is responsible for damage occurring in transit. Martin Engineering CANNOT enter claims for damages. Contact your transportation agent for more information.**

1. Inspect shipping container for damage. Report damage to delivery service immediately and fill out delivery service's claim form. Keep any damaged goods subject to examination.
2. Remove air cannon from shipping container. Equipment in container should include the following:
  - Air cannon, relief valve, and pipe nipple.
  - Air Blast Warning Label, P/N 31913.
  - Lockout Valve Warning Tag, P/N 35146.
3. If you ordered accessories from Martin Engineering, remove from shipping container. Equipment in container may include the following:
  - Quick exhaust valve.
  - Air control components: manual valve or electrical solenoid valve, air filter/regulator/lubricator, air supply line, lockout ball valve, and check valve.
4. If anything is missing, contact Martin Engineering or representative.

## **⚠ WARNING**

**Before installing air cannon, lock out/tag out any equipment that is loading or unloading material from the storage vessel.**

5. Turn off and lock out/tag out energy source to accessory equipment according to ANSI standards (see "References").

## **⚠ WARNING**

**If equipment will be installed in an enclosed area, test gas level or dust content before using a cutting torch or welding. Using a cutting torch or welding in an area with gas or dust may cause an explosion.**

6. If using a cutting torch or welding, test atmosphere for gas level or dust content.

**⚠ CAUTION**

**When blasting into closed storage vessel, exhaust vents must be considered to prevent internal vessel air pressure from increasing to point where it may damage vessel.**

7. When blasting into closed storage vessel, consider exhaust vents to prevent internal vessel air pressure from increasing to point where it may damage vessel. Calculate temporary vessel pressure after air cannon discharge with the following equation:

$$P = \frac{\text{pressure in air cannon} \times \text{air cannon volume}}{\text{air cannon volume} + \text{unoccupied volume of vessel}}$$

If calculated pressure is greater than 0.5 psi (.034 bar), install exhaust vents to avoid damage to storage vessel. Observe local and state codes, which may specify limits less than 0.5 psi (.034 bar).

**IMPORTANT**

**Air cannon force output can vary depending on inlet pressure, discharge opening size, structure size, material in structure, and other factors. To determine maximum force output values for your application, call Martin Engineering.**

8. If you need to know air cannon maximum force output for your application, call Martin Engineering.

# Installing Air Cannon

## IMPORTANT

Read entire section before beginning work.

To install air cannon, follow the procedures in this section corresponding to the following steps:

1. Install mounting plate.
2. Connect air cannon to mounting plate.
3. Install restraining cable.
4. Connect air supply to air cannon. See “Installing manual valves and electrical solenoid valves” or “Installing solenoid enclosures,” as applicable.

### *Installing mounting plate*

Materials Required: Mounting plate or seal plate and support structure.

## NOTE

**If you are unsure where to locate air cannon(s) on your storage vessel, contact Martin Engineering or your representative.**

1. Mark location for each air cannon on storage vessel.
2. For internal storage vessel temperatures under 500°F (260°C), install standard (30°) or fan jet mounting plate on vessel as follows:
  - a. If using a standard mounting plate (Figure 5), cut a round hole 4-5/8 in. (117 mm) in diameter in storage vessel for each mounting plate. Place short nipple into hole and field weld mounting plate to vessel skin.

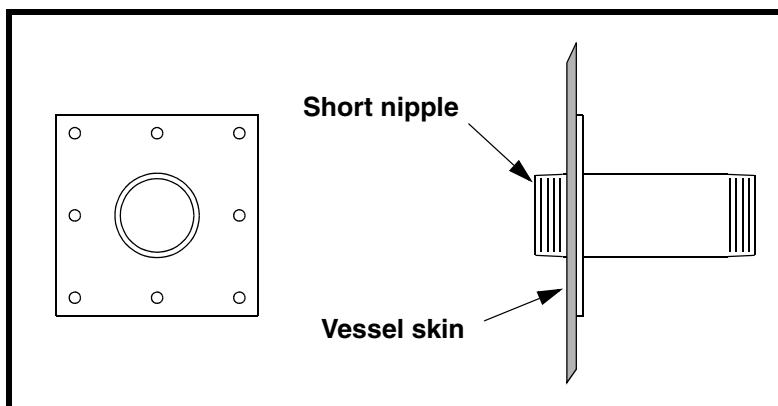

**Figure 5. Standard Mounting Plate**

- b. If using a 30° mounting plate (Figure 6), cut a hole in storage vessel for each mounting plate using templates on last page of this manual. If templates are missing, contact Martin Engineering or representative. Place mounting plate over hole and field weld to vessel skin.

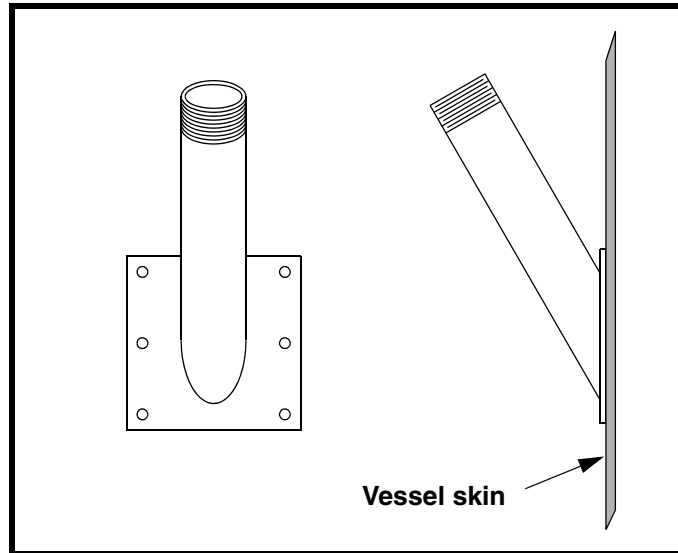

**Figure 6. 30° Mounting Plate**

- c. If using a fan jet mounting plate (Figure 7), cut a round hole in storage vessel for each mounting plate or use template on last page of this manual. Slide nipple through hole from inside. Field weld inside plate and nipple to vessel wall.
- d. Go to “Connecting air cannon to mounting plate.”

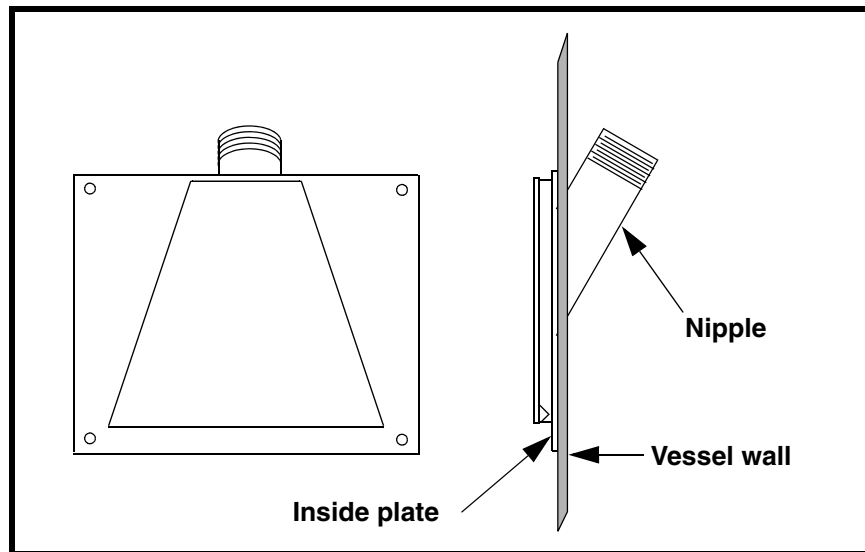

**Figure 7. Fan Jet Mounting Plate**

3. For internal storage vessel temperatures of 500°F (260°C) or higher, install XHV blow pipe and fan jet angle nozzle, fan jet blow nozzle, or high-temperature blow pipe (Figure 8) on vessel as follows:
  - a. If using fan jet angle nozzle, contact Martin Engineering.

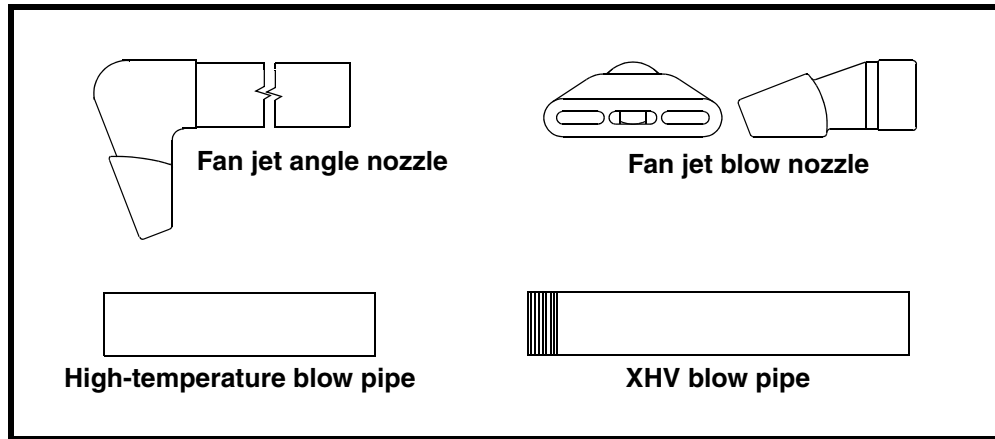

**Figure 8. Mounting Nozzles/Pipes (High-Temperature Applications)**

- b. If using fan jet blow nozzle, do the following:
  - (1) Cut a 15-in. (381 mm) by 6-in. (152 mm) hole in skin and refractory (A, Figure 9) (if present).
  - (2) If using high-temperature blow pipe, field weld onto fan jet blow nozzle.

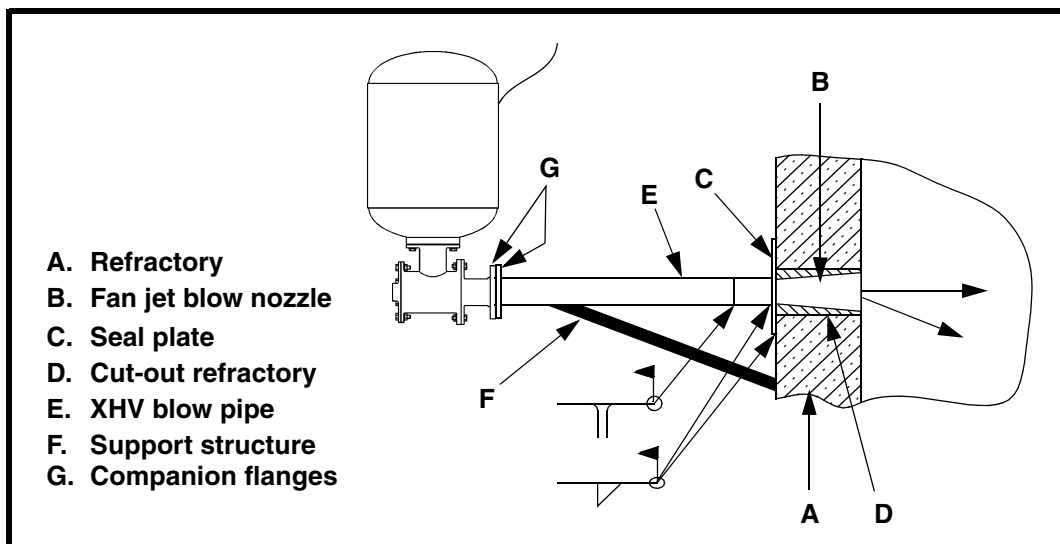

**Figure 9. Installing Mounting Plate (High-Temperature Applications)**

- (3) Insert fan jet blow nozzle (B) in hole with nozzle face flush with refractory lining surface. Position fan jet blow nozzle to sweep adjacent wall when cannon discharges (see Figure 10).

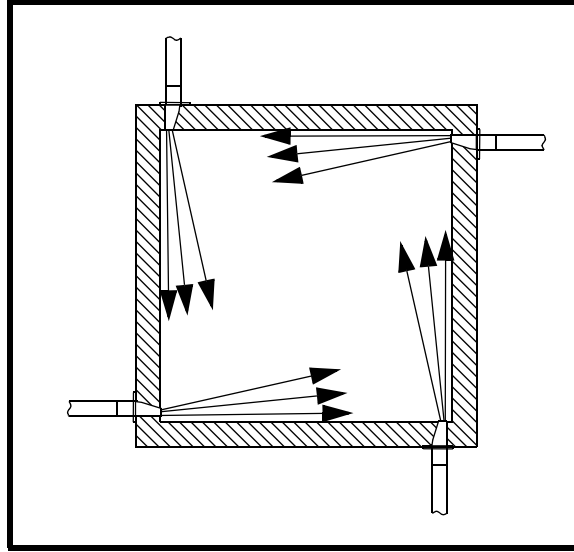

**Figure 10. Riser Duct with Fan Jet Blow Nozzles (High-Temperature Applications)**

- (4) Install 1/4-in. (6 mm) thick by 17-in. (432 mm) long by 8-in. (203 mm) wide seal plate (C, Figure 9) over fan jet blow nozzle opening.
- (5) Field weld seal plate to vessel skin.
- (6) Field weld fan jet blow nozzle to seal plate.
- (7) Pack new refractory into hole that you cut out (D) in step 3.b(1) to seal around fan jet blow nozzle.
- (8) Field weld XHV blow pipe to high-temperature blow pipe (if using) or fan jet blow nozzle.
- (9) Go to step 3.d.

### IMPORTANT

**XHV blow pipe can be installed alone as described in step 3.c. However, if using high-temperature blow pipe, also install XHV blow pipe as described in step 3.c.(5).**

- c. If using high-temperature blow pipe and/or XHV blow pipe, do the following:
  - (1) Cut a 5-in. (127 mm) round hole in skin and refractory (A, Figure 9) (if present).
  - (2) Insert blow pipe (B) in hole with pipe end flush with refractory lining surface. Position blow pipe to sweep walls when cannon discharges (see Figure 11).
  - (3) Install 1/4-in. (6 mm) thick by 8-in. (203 mm) long by 8-in. (203 mm) wide seal plate (C, Figure 9) over blow pipe opening in **one** of the following ways:
    - (a) Cut seal plate in half and fit around blow pipe.
    - (b) Cut a 5-in. (127 mm) round hole in seal plate and install over end of blow pipe.

- (4) Field weld seal plate to vessel skin.
- (5) Field weld blow pipe to seal plate.

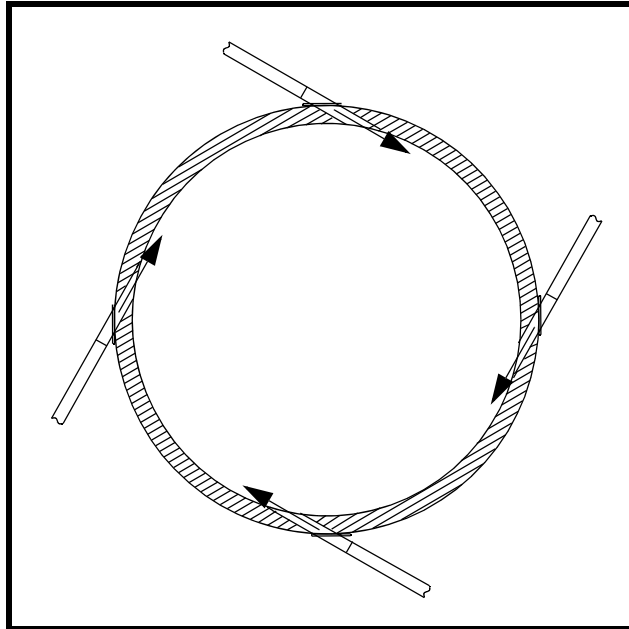

**Figure 11. Cyclone with High-Temperature Blow Pipes**

- (6) Pack new refractory into hole that you cut out (D) in step 3.c(1) to seal around high-temperature blow pipe.
  - (7) If using high-temperature blow pipe, field weld XHV blow pipe to high-temperature blow pipe.
- d. Go to “Connecting air cannon to mounting plate.”

***Connecting air cannon to mounting plate***

1. Thread (and weld, if desired) one companion flange (G, Figure 9) to XHV blow pipe and other companion flange to XHV discharge weldment.
2. Bolt flange on discharge weldment to flange on blow pipe.
3. Position tank with inspection ports downward to provide maximum drainage.
4. Go to “Installing restraining cable.”

## Installing restraining cable

### **⚠ WARNING**

If air cannon is mounted more than 6 in. (152 mm) above ground, install restraining cable to secure air cannon to storage vessel. Without restraining cable, air cannon could fall and cause injury.

Do not use restraining cable to mount air cannon to storage vessel wall. Purpose of restraining cable is to keep air cannon from falling should it come loose from vessel wall, not as primary means of securing air cannon to wall.

### **⚠ CAUTION**

Do not use angle iron or support ring to secure air cannon rigidly to storage vessel. If restrained too rigidly, tank cannot flex and cannon can fail.

1. Weld D-ring (A, Figure 12) onto storage vessel (B) with 1/4-in. (6-mm) field weld.

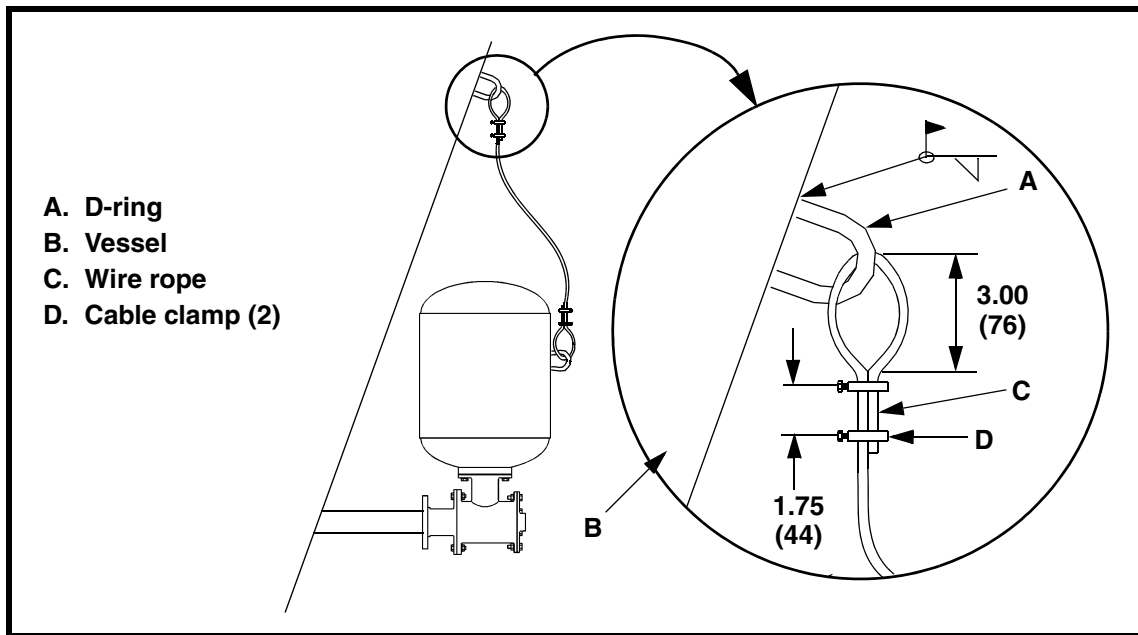

**Figure 12. Installing Restraining Cable**

2. Insert wire rope (C) through D-ring on storage vessel, making a 3-in. (76-mm) loop. If wire rope supplied with air cannon is not long enough, loop and clamp it to an additional cable and attach additional cable to air cannon.
3. Clamp wire rope with one cable clamp (D) as close to loop as possible. Place another cable clamp 1-3/4 in. (44 mm) from first clamp.
4. Leave at least 1 in. (25 mm) of wire rope on dead end.
5. Gradually tighten nuts alternately and evenly to 15 ft-lbs. Leave 2 to 3 in. (51 to 76 mm) slack in wire rope.
6. Go to “Connecting air supply to air cannon.”

*Connecting air  
supply to air  
cannon*

**IMPORTANT**

Read entire section before beginning work.

**⚠ CAUTION**

When pressure in the storage vessel is 4 psi (0.28 bar) or more, apply equal or greater pressure to the air cannon inlet. Absence of inlet pressure will allow material in the storage vessel to enter the air cannon and contaminate the valve body and tank.

**Installing manual valves and electrical solenoid valves**

Materials Required:

- Air filter/regulator/lubricator (1/2-in. NPT).
- Bushing (1/2-in. by 3/4-in.).
- Check valve (1/2-in. NPT).
- Lockout ball valve (1/2-in. NPT).
- Manual 3-way valve or electrical solenoid valve (1/2-in.).
- MARTIN® Air Motor Oil.
- Pipe (1/2-in. NPT).
- Quick exhaust valve (1-in.).
- 90° street elbow (optional for quick exhaust valve—1-in.).
- 90° street elbow (optional for manual or electrical solenoid valves—3/4-in.).

**IMPORTANT**

**To prevent leaking, apply pipe sealant to all fittings. Air cannon will discharge randomly if leaks are present.**

1. Apply pipe sealant to all fittings.

**⚠ WARNING**

**Use ASME-approved relief valve only (supplied with XHV Air Cannon).**

2. Remove dust cap from tank inspection port and install relief valve (A, Figure 13 or 14). Make sure other inspection ports are tightly plugged.

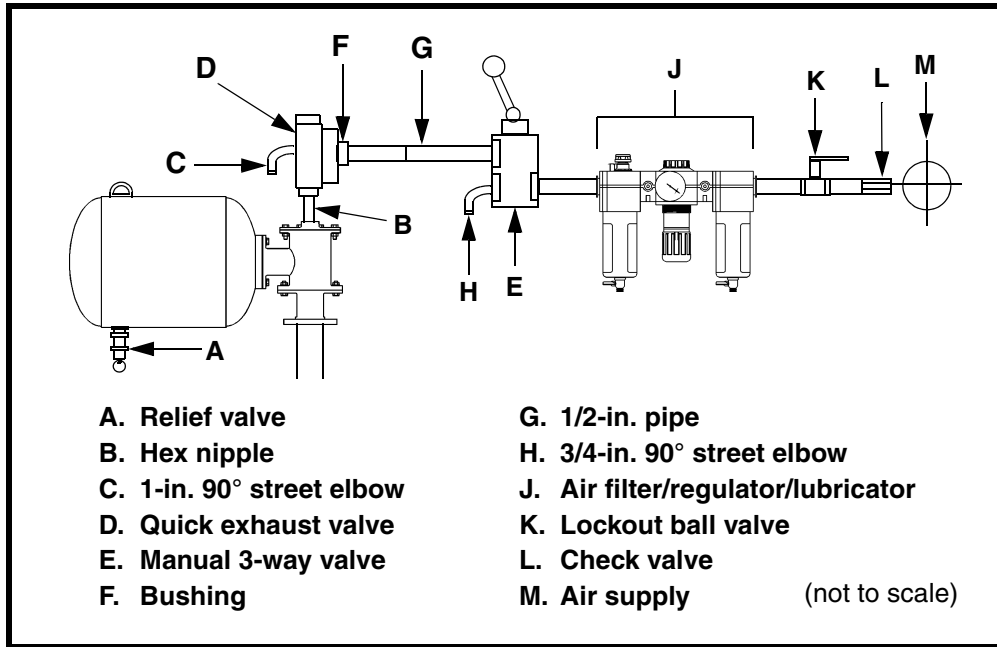

**Figure 13. Manual Valve Piping**

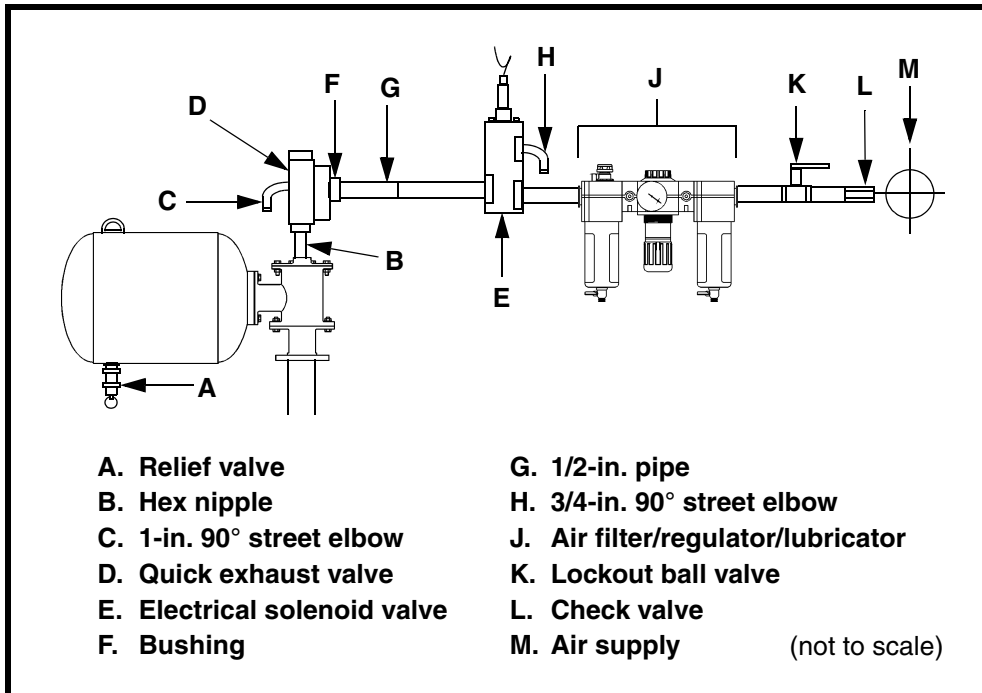

**Figure 14. Electrical Solenoid Valve Piping**

**WARNING**

**Make sure exhaust port on quick exhaust valve is pointed downward so that dirt cannot enter, and exhaust port is not directed at personnel. Martin Engineering recommends installing a 90° street elbow on quick exhaust valve exhaust port and on manual or electrical solenoid valve exhaust ports to prevent dirt from entering.**

3. If using optional 90° street elbow (C) for quick exhaust valve, thread it into quick exhaust valve exhaust port (D).
4. Thread quick exhaust valve outlet port (with exhaust port pointed down) onto hex nipple and tighten.

**IMPORTANT**

**Manual valves or electrical solenoid valves distributed by Martin Engineering, which are made especially for this air cannon, are recommended. Substitute valves may not work as effectively.**

**Use any length pipe to connect air filter/regulator/lubricator to check valve. Use 1/2-in. pipe only. Locate manual valve or electrical solenoid valve within 15 ft (4-1/2 m) of air cannon.**

5. Choose location for manual 3-way valve (E, Figure 13) or electrical solenoid valve (E, Figure 14).
6. Install bushing (F, Figure 13 or 14) into quick exhaust valve inlet port.
7. Connect manual 3-way valve or electrical solenoid valve outlet port to bushing/quick exhaust valve inlet port with no more than 15 ft (4-1/2 m) of 1/2-in. pipe (G).
8. Install 90° street elbow (H) for manual 3-way valve or electrical solenoid valve into valve exhaust port.

**NOTE**

**Look at arrow on side of FRL, check valve, and lockout ball valve to make sure flow is correct.**

9. Connect air filter/regulator/lubricator (J) and manual 3-way valve or electrical solenoid inlet port with desired length 1/2-in. pipe.

**IMPORTANT**

**OSHA requires installation of a lockout ball valve (see “References”).**

10. Connect lockout ball valve (K) to air filter/regulator/lubricator with desired length 1/2-in. pipe. Look at arrow on side of ball valve to make sure flow is correct.
11. Fill lubricator with MARTIN® High-Temperature Oil. Set lubricator to release one drop per hour.
12. Connect check valve (L) to lockout ball valve with desired length 1/2-in. pipe. Look at symbol on side of check valve to make sure flow is correct.

**IMPORTANT**

For electrical solenoid valve installations, design and wire electrical solenoid controls according to NEC Handbook. Electrical push buttons, timers, and programmable controllers are available through Martin Engineering.

13. For electrical solenoid valve installations, if using electrical solenoid controller, install according to instructions provided with controller.

**⚠ WARNING**

Do not exceed 125 psi (8.62 bar) maximum working pressure or pressure relief valve will open. Minimum recommended pressure for most applications is 80 psi (5.52 bar) but lower pressures can be used. Make sure air supply is filtered and regulated.

**NOTE**

Pressure relief valves of up to 150 psi are available from Martin Engineering. Consult the Maximum Allowable Working Pressure (MAWP) on tank's name plate before substituting a different pressure relief valve. Never use a pressure relief valve with a set pressure that is higher than the MAWP of the tank.

**⚠ WARNING**

Pressure relief valve may relieve at any point between 90% and 100% of set pressure. Exceeding MAWP can cause tank to rupture.

14. Connect air supply (M) to check valve.
15. Anchor all pipes and wires to prohibit movement.
16. Operate air cannon as described under “After Installing Air Cannon.”

***Installing solenoid enclosures***

Materials Required:

- Air filter/regulator/lubricator (1/2-in. NPT).
- Bushing (3/4-in. to 3/8-in. NPT).
- Check valve (1/2-in. NPT).
- Controller.
- Lockout ball valve (1/2-in. NPT).
- Male adapter fittings (3/8-in. Tubing to 3/8-in. NPT).
- Solenoid enclosure.
- MARTIN® High-Temperature Oil.
- Pipe (1/2-in. NPT).
- Quick exhaust valve (1-in.).
- Stainless steel tubing (3/8-in.).
- 90° street elbow (optional for quick exhaust valve—1-in.).

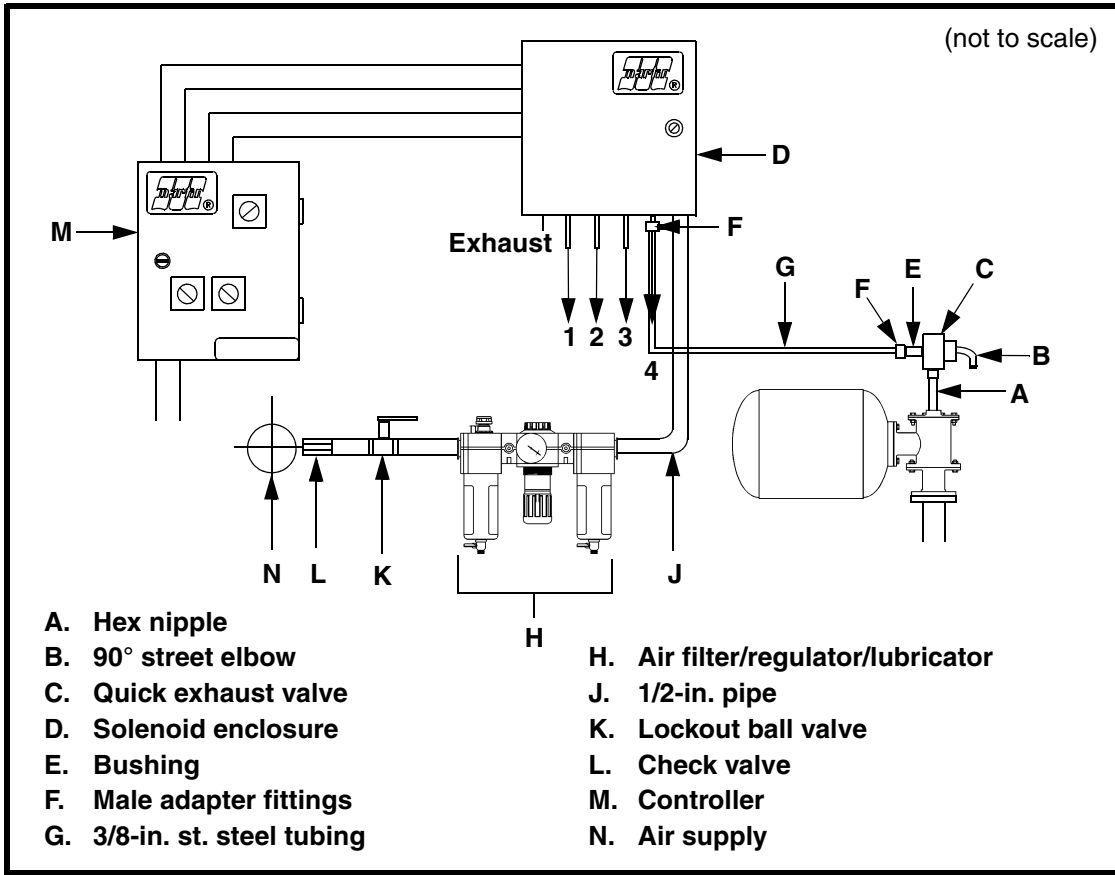

Figure 15. Solenoid Enclosure Piping

**IMPORTANT**

Solenoid enclosures distributed by Martin Engineering, which are made especially for this air cannon, are recommended. Substitute enclosures may not work as effectively.

Install a quick exhaust valve for every 25 ft (8 m) of stainless steel pipe from solenoid enclosure to air cannon, or air cannon will not work as intended.

**CAUTION**

Do not use solenoid enclosure in explosive environment. Solenoid enclosure is not rated for hazardous locations.

1. Refer to Figure 15 and follow steps 1 through 4 under “Installing manual valves and electrical solenoid valves.”
2. Choose location for solenoid enclosure (D) and mount with bulkhead fittings pointing down.
3. Connect quick exhaust valve to solenoid enclosure as follows:
  - a. Install bushing (E) on quick exhaust valve (C). Install a male adapter fitting (F) on bushing and on solenoid enclosure (D).
  - b. Connect the two male adapter fittings with 3/8-in. stainless steel tubing (G).

## NOTE

**Look at symbol on side of FRL, check valve, and lockout ball valve to make sure flow is correct.**

4. Connect air filter/regulator/lubricator (H) to solenoid enclosure (D) inlet line with desired length 1/2-in. pipe (J).

## IMPORTANT

**OSHA requires installation of a lockout ball valve (see “References”).**

5. Connect lockout ball valve (K) to air filter/regulator/lubricator with desired length 1/2-in. pipe.
6. Fill lubricator with MARTIN® High-Temperature Oil. Set lubricator to release one drop per hour.
7. Connect check valve (L) to lockout ball valve with desired length 1/2-in. pipe.

## IMPORTANT

**Connect all solenoid enclosures to a controller. Design and wire solenoid cabinet controls according to NEC Handbook. Electrical push buttons, timers, and programmable controllers are available through Martin Engineering.**

8. Drill conduit entrance hole in solenoid enclosure for wiring.
9. Connect conduit according to NEC Handbook standards.
10. Wire solenoid enclosure to a mechanical, programmable, or solid-state controller according to controller’s operating manual.
11. Connect air supply (N) to check valve (L).
12. Anchor all pipes and wires to prohibit movement.
13. Operate air cannon as described under “After Installing Air Cannon.”

# After Installing Air Cannon

---

## **IMPORTANT**

**Read entire section before beginning work.**

1. Thoroughly wipe storage vessel wall clean next to vessel door/port. Place Air Blast Warning Label, P/N 31913, on vessel wall visible to anyone opening door/port. If more than one door or port exists on storage vessel, request additional labels from Martin Engineering or representative. Attach Lockout Valve Warning Tag, P/N 35146, to lockout valve with cable tie (supplied).
2. Purge air lines.

## **IMPORTANT**

**Charge each air cannon individually during initial start-up to avoid significant pressure loss.**

**Relief valve is preset to open at 125 psi (8.62 bar).**

## **⚠ WARNING**

**Do not exceed 125 psi (8.62 bar) maximum working pressure or pressure relief valve will open. Minimum recommended pressure for most applications is 80 psi (5.52 bar) but lower pressures can be used. Make sure air supply is filtered and regulated.**

## **NOTE**

**Pressure relief valves of up to 150 psi are available from Martin Engineering. Consult the Maximum Allowable Working Pressure (MAWP) on tank's name plate before substituting a different pressure relief valve. Never use a pressure relief valve with a set pressure that is higher than the MAWP of the tank.**

## **⚠ WARNING**

**Pressure relief valve may relieve at any point between 90% and 100% of set pressure. Exceeding MAWP can cause tank to rupture.**

3. Supply 80 to 125 psi (5.52 to 8.62 bar) filtered, regulated, and lubricated air to system.
4. For air cannons with manual valves, position manual valve lever so air is supplied to air cannon (inlet to outlet open).
5. If air cannon does not charge, see “Troubleshooting.”
6. Check system for air leaks. If leaking, see “Troubleshooting.”

**NOTE**

When air cannon blasts, a small amount of air will release from solenoid valve and quick exhaust valve.

**⚠ DANGER**

Do not open door/port or enter storage vessel when cannons are charged and operational. Flying debris from cannons' blast can kill you.

If air cannons are installed on open pit or on structure with no top, make sure area is clear before firing cannons. Flying debris from cannons' blast can kill you.

Air cannons are loud when firing. Use ear protection to avoid impairment or loss of hearing.

7. Blast air cannon as follows:
  - a. For air cannons with manual valves, move manual valve lever to opposite position (inlet to outlet closed, outlet to exhaust open).
  - b. For air cannons with electrical solenoid valves and external electrical controls, activate electrical solenoid valve by external control (electrical push button, timer, etc.) or by pushing button on electrical solenoid valve. (If wired correctly, this should send signal to solenoid valve closing inlet to outlet and opening outlet to exhaust.)
  - c. For air cannons with solenoid enclosure and controller, set up controller according to controller's operating manual. Use controller to activate solenoid cabinet.
8. Blast air cannon five times to ensure proper operation. Allow tank to fill after each blast.
9. If air cannon blasts properly, continue to operate air cannon as needed. If problems occur, see "Troubleshooting."
10. Keep air cannon charged with air at all times so unit is always ready for use, and so material cannot flow into air cannon.

## IMPORTANT

Read entire section before beginning work.

## DANGER

**Turn off and lock out/tag out air supply and energy source before blasting air cannon to prevent air cannon from refilling.**

**Do not open door/port or enter storage vessel before turning off compressed air source, locking out controls, purging line pressure, and venting air from tank.**

**Shutting off lockout ball valve will purge all cannons connected to that valve and cause the air cannons to fire immediately. Do not shut off the valve until you make sure no one is in the structure or near its discharge. Flying debris from the cannons' blast can kill you.**

Turn off and lock out/tag out energy source according to ANSI standards (see "References").

### *Every month*

1. Inspect all connections from air supply to tank for leaks and deterioration. If connections are leaking, seal all fittings with pipe sealant and tighten. Replace any deteriorating connections. Make sure hoses do not flex more than 1/4 in. (6 mm).
2. Make sure all pipes and wires are anchored to prohibit movement. Secure as needed.
3. Inspect quick exhaust valve, manual valve or electrical solenoid valve, check valve, lockout ball valve, and air filter/regulator/lubricator for proper operation. If not operating correctly, replace.
4. Wipe all warning labels clean. If labels are not readable, contact Martin Engineering or representative for replacements.

## *Every year or 50,000 firings*

1. Blast air cannon to remove air from tank, then pull ring on relief valve to make sure air stored in cannon has been released.
2. Perform monthly maintenance. See “Every month.”

### **▲ WARNING**

**Do not remove drain plug until air has been released from tank, or air cannon will discharge.**

3. After all air is released, remove drain plug. Allow all moisture to drain from tank.
4. After all moisture is removed, apply pipe sealant to drain plug. Install drain plug on tank.

### **▲ CAUTION**

**Do not weld tank. Paint in tank will melt and welding will violate ASME code. If tank is damaged or leaking, do not use air cannon until tank is replaced or repaired by Martin Engineering.**

5. Inspect air cannon mounting area for rust and loose screws, welds, and bolts. Replace, tighten, or weld as necessary.
6. Inspect tank, valve body, piston, and discharge nozzle for damage. Replace or return to Martin Engineering for repair as necessary.
7. Inspect restraining cable for wear. Replace if worn.
8. Inspect quick exhaust valve for loose screws or dirt. Tighten and clean as necessary. Inspect rubber diaphragm in quick exhaust valve. If worn, replace. (Repair kit available from Martin Engineering or representative.)
9. On units with electrical controls, inspect wires and connections. Repair or replace wires to NEC Handbook standards as necessary.

# Troubleshooting

If the air cannon will not charge or discharge, or if the electrical solenoid valve will not operate, find the possible cause(s) in the appropriate chart below and follow the steps in the “Solution” column.

<b>Problem: Air Cannon Will Not Charge</b>	
<b>Cause</b>	<b>Solution</b>
Shut-off valve not turned on.	Turn on valve.
Quick exhaust valve installed improperly.	Make sure air supply line is connected to correct ports.
Quick exhaust valve dirty or damaged.	Clean or replace quick exhaust valve or valve piston.
Air cannon not mounted correctly, and tank is full of material.	Clean or replace tank. Check Mounting Instructions.
Tank inspection plug(s) loose.	Tighten plug(s).
Tank punctured or cracked.	Replace tank.
Restriction in air supply line.	Remove restriction and check air filter/regulator/lubricator.
Restriction in quick exhaust valve or valve body.	Check both valves and remove restriction. Check filter.
Air compressor too small.	Use larger air compressor.
Electrical solenoid valve is not #125, 3-way normally-opened valve.	Replace valve.

<b>Problem: Air Cannon Will Not Discharge</b>	
<b>Cause</b>	<b>Solution</b>
Quick exhaust valve improperly installed.	Make sure air supply line is connected to correct ports.
Quick exhaust valve dirty or damaged.	Clean or replace quick exhaust valve or valve diaphragm. Check lubricator for oil and set drops per minute.
Quick exhaust valve exhaust port blocked.	Open exhaust port to atmosphere.
Electrical solenoid valve is not #125, 3-way normally-opened valve.	Replace valve.
Manual or solenoid valve not installed properly.	Check all connections from tank to air supply. Make sure pipes are 1/2-in. NPT.
Supply line too large diameter.	Replace with 3/8-in. tubing for solenoid cabinet installation, and 1/2-in. pipe for all others.
Solenoid valve located too far away from quick exhaust valve.	Move to within 25 ft (7.62 m) on 3/8-in. tubing application, and 15 ft (4.57 m) on 1/2-in. tubing application.
Valve body full of foreign matter.	Disassemble and clean out.

<b>Problem: Electrical Solenoid Valve Will Not Operate</b>	
<b>Cause</b>	<b>Solution</b>
Defective solenoid valve. (Check the valve by connecting to another output. Low resistance across coil indicates good valve.)	Remove piping from exhaust port of solenoid. If this causes solenoid to operate properly, use larger piping or remove restriction. Replace valve.
Broken lead to solenoid valve.	Replace wire to NEC Handbook Standards.
Defective timer.	Replace timer.

## IMPORTANT

Read entire section before beginning work.

Refer to Figure 16 in the “Part Numbers” section when following these repair procedures.

## *Disassembly*

## ⚠ WARNING

Turn off and lock out/tag out air supply and energy source before blasting air cannon to prevent air cannon from refilling. Failure to do so could result in injury to personnel and damage to equipment.

Do not open door/port or enter storage vessel before turning off compressed air source, locking out controls, purging line pressure, and venting air from tank.

## ⚠ DANGER

Shutting off lockout ball valve will purge all cannons connected to that valve and cause the air cannons to fire immediately. Do not shut off the valve until you make sure no one is in the structure or near its discharge. Flying debris from the cannons’ blast can kill you.

1. Turn off and lock out/tag out energy source according to ANSI standards (see “References”).
2. Blast air cannon several times to remove air from tank (1), then pull ring on relief valve (14) to make sure air stored in cannon has been released.
3. Disconnect air line from quick exhaust valve (13).

## ⚠ WARNING

Remove hex head cap screws and nuts from cap carefully so spring tension does not knock cap off. Failure to remove cap with care could result in injury to personnel and damage to equipment.

4. Remove hex head cap screws (9), nuts (12), and compression washers (11) from cap assembly (6).
5. Remove cap assembly, spring (5), and piston (3) from valve body (2).

## NOTE

**Disconnect tank only if piston seat needs replacement. Read “Inspection” before removing tank.**

6. Before disconnecting tank and valve body from storage vessel, make sure restraining cable is strong and undamaged, and will allow tank to swing to side.
7. Remove tank from pipe flange and place tank on stable surface for repair.
8. If necessary, remove piston seat (4) from valve body as follows:
  - a. Make sure cap assembly, spring, and piston have been removed from valve body.
  - b. Remove hex head cap screws, nuts, and compression washers securing discharge flange weldment (8) to valve body.

## CAUTION

**Remove discharge flange weldment carefully so piston seat doesn't fall out of valve body. If piston seat is loose, it could fall and be damaged.**

- c. Carefully remove discharge flange weldment and pull piston seat from valve body.

## *Inspection*

1. Inspect piston and bearing in valve body for damage or wear. Replace parts if necessary.
2. Inspect piston seat sealing edge for damage or wear. Replace parts if necessary.

## NOTE

**If you remove quick exhaust valve, make sure you re-install it into proper port.**

3. Inspect quick exhaust valve (13) for damage and wear. Replace if necessary.
4. Inspect bore on valve body (2) for grooves, burrs, or corrosion. If damaged or worn, replace valve body.
5. Inspect o-rings in cap and seat. Replace if necessary.

## *Assembly*

1. If removed, insert piston seat into valve body and replace eight hex head cap screws, compression washers, and nuts. Tighten to 154 ft-lb (209 N·m) in cross pattern.
2. Insert piston and spring into valve body.
3. Make sure o-ring (10) is in place on valve body cap and install on valve body using hex head cap screws, compression washers, and nuts. Tighten to 154 ft-lb (209 N·m) in cross pattern.
4. Connect air line to quick exhaust valve.

## Notes

## Part Numbers

---

This section provides product names and corresponding part numbers for BIG BLASTER® XHV Air Cannons and related equipment. Please reference part numbers when ordering parts. Part numbers for accessory equipment not listed here are available from Martin Engineering or representative.

### ***BIG BLASTER® XHV Air Cannons***

**6-in. Discharge Air Cannon Assembly:** See Figures 16a and 16b.

**Model BB6-20-30:** P/N 36260-2030

**Model BB6-24-48:** P/N 36260-2448

**Model BB6-30-60:** P/N 36260-3060

**4-in. Discharge Air Cannon Assembly:** See Figures 17a and 17b.

**Model BB4-12-28:** P/N 35132-1228

**Model BB4-20-30:** P/N 35132-2030

**Model BB4-24-48:** P/N 35132-2448

**Model BB4-30-60:** P/N 35132-3060

**2-in. Discharge Air Cannon Assembly:** See Figures 18a and 18b.

**Model BB2-8-12:** P/N 35859-0812

**Model BB2-8-20:** P/N 35859-0820

### ***Mounting accessories***

**6-in. 90° Mount Plate:** P/N 36445

**6-in. 30° Mount Plate:** P/N 36452

**6-in. XHV Blow Pipe:** P/N 36483

**6-in. High-Temperature Blow Pipe:** P/N 36574

**4-in. 90° Mount Plate:** P/N 20881

**4-in. 30° Mount Plate:** P/N 23024

**4-in. Fan Jet Assembly:** P/N 22607

**4-in. Fan Jet Blow Nozzle (High-Temperature):** P/N 29954

**4-in. Fan Jet Angle Nozzle (High-Temperature):** P/N 29953

**4-in. XHV Blow Pipe:** P/N 35218

**4-in. High-Temperature Blow Pipe:** P/N 29952

**2-in. 90° Mount Plate:** P/N 21629

**2-in. 30° Mount Plate:** P/N 20305

**2-in. Fan Jet Assembly:** P/N 21919

**2-in. XHV Blow Pipe:** P/N 36506

**2-in. High-Temperature Blow Pipe:** P/N 37033

***Air control  
components/kits***

**BBAC Air Line Kit:** P/N 24679-01. Includes 1/2-in. check valve, ball valve, and filter/regulator/lubricator.

**BB4 XHV Installation Kit:** P/N 35150. Includes QEV, flanges, hardware, gasket, 1-in. street elbow, and 1-in. hex nipple.

**Fill Control Kit:** P/N 33739. Includes fitting, union, bushing, and tube.

**1/2-in. Filter:** P/N 14751

**1/2-in. L8 Lubricator:** P/N 14756

**1/2-in. Air Filter/Regulator/Lubricator:** P/N 14760

**1/2-in. FL81 Filter/Lubricator:** P/N 14761

**Manual 1/2-in. Valve:** P/N 20817

**125# Solenoid Valve 1/2-in. Ports:** P/N 36343

**1/2-in. Check Valve:** P/N 22618

**BB4 Plumbing Kit:** P/N 26405-01. Includes: 1" quick exhaust valve, 1" hose assembly, flange assembly, 1/2" N.O. 1154 solenoid valve, 1" street elbow.

**BB2 XHV Installation Kit:** P/N 37032. Includes: quick exhaust valve, 1" pipe nipple, 2" screwed flange assembly, 1" street elbow.

**BB2 XHV Plumbing Kit:** P/N 36507. Includes: 1" quick exhaust valve, 1" NPT pipe nipple, flange assembly, 1/2" N.O. 1154 solenoid valve, 1" street elbow.

**BB4 Accessory Kit:** P/N 26405. Includes: 1" quick exhaust valve, 1" hose assembly, flange assembly, 1" street elbow.

**BB6 XHV Installation Kit:** P/N 36433. Includes: 2 pipe nipples, 2 quick exhaust valves, flange assembly, (2) 1" street elbows, stainless steel tube and fittings.

**BB6 XHV Plumbing Kit:** P/N 36434. Includes: 2 pipe nipples, 2 quick exhaust valves, flange assembly, solenoid valve, stainless tube and fittings, (2) 1" street elbows.

**4-Bank Solenoid Enclosure:** P/N 36279-04

**5-Bank Solenoid Enclosure:** P/N 36279-05

**Air Gauge Accessory Kit:** P/N 34843

**Fill Control Line Kit:** P/N 33739. Includes: (4) 3/8" x 20 ga x 5' long pieces of 304 stainless steel tubing and fittings.

***Miscellaneous***

**MARTIN® High-Temperature Oil:** Quart P/N 34528-Q, Case (12 qts), P/N 34528-C

**Restraining Cable Kit (6 ft):** P/N 32271

**BBAC Controller (115v/220v):** P/N 36756

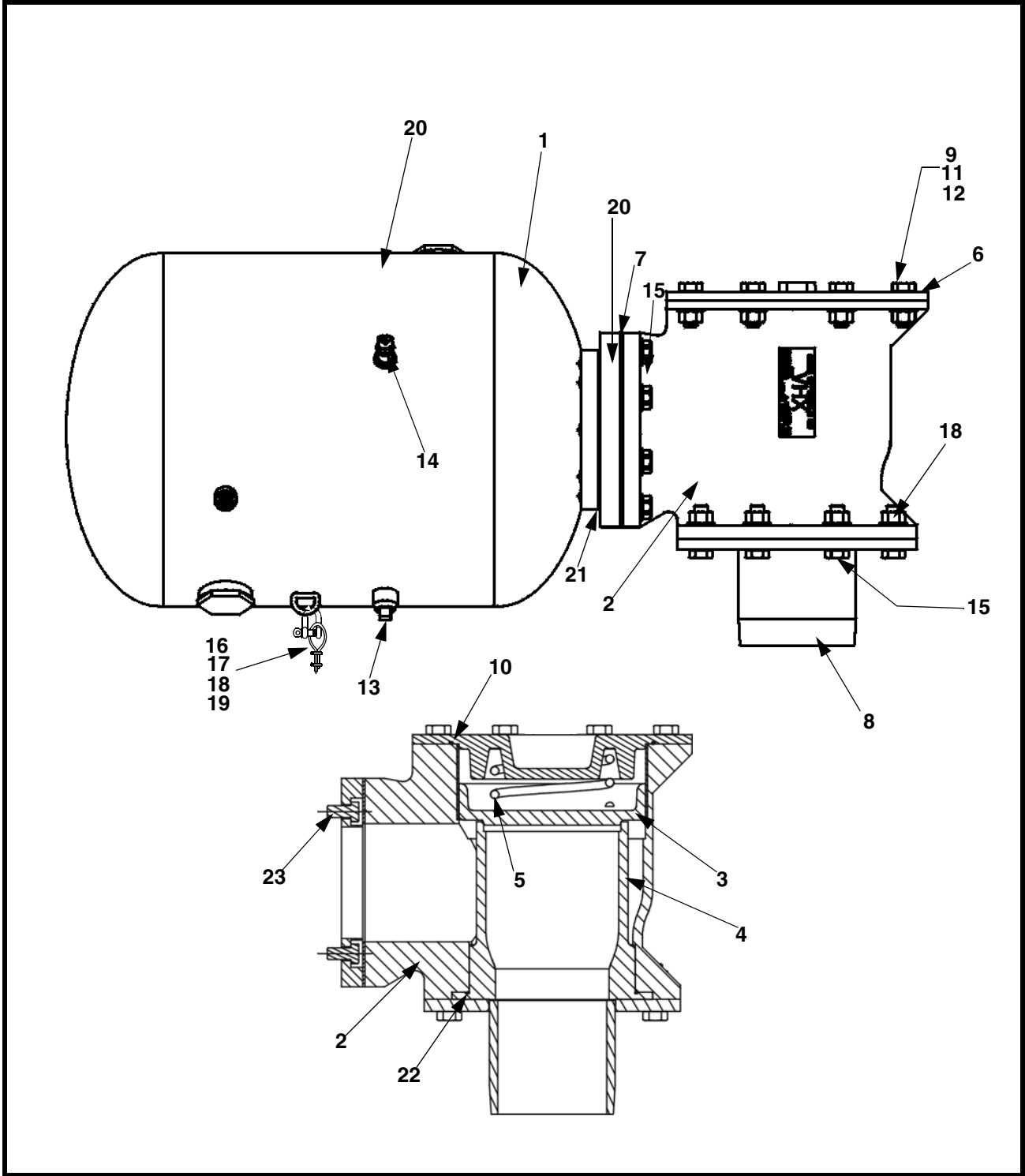

Figure 16a. BIG BLASTER® XHV 6-in. Air Cannon Assembly, P/N 36260-XXXX

Item	Description	Part No.	Qty
1	Tank Weldment	See Table I	1
2	Valve Body	36114	1
3	Piston with Urethane	37963	1
4	Piston Seat	36113	1
5	Compression Spring	36167	1
6	Cap	36111	1
7	Tank Gasket	36263	1
8	Discharge Flange Weldment	36170	1
9	Screw HHC 3/4-10 NC x 2 ZP	19135	16
10	O-Ring #275 10.484 ID x .139 CS	36169	1
11	Washer Compression 3/4	11754	24
12	Nut Hex 3/4-10 NC ZP	11773	16
13	Plug SQ HD 3/4 NPT	18446-01	1
14	Safety Relief Valve	21680	1
15	Screw HHC 5/8-10 NC x 2-1/2 ZP	17770	8
16	Shackle 1/2	32856	1
17	Cable Clamp 1/4	32264	4
18	Wire Rope 1/4	100258	6
19	D-Ring	32265	1
20	Flange Transition	36261	1
21	Transition Gasket	36173	1
22	O-Ring #174 8.737 ID	36262	1
23	Screw HHC 5/8-11 NC x 1-1/4 ZP	15798	8
**	Label Kit	34517-03E	1
*	Operator Manual	M3404	1

\*Not Shown

\*\*Refer to Appendix B

**Figure 16b. BIG BLASTER® XHV 6-in. Air Cannon Assembly Parts List**

**Table I. BIG BLASTER® XHV 6-in. Air Cannon Tank Weldment Part Numbers**

Part No.	Part No. Item 1
36260-2030	31027-2030
36260-2032	33641-150
36260-2448	31027-2448
36260-3060	31027-3060

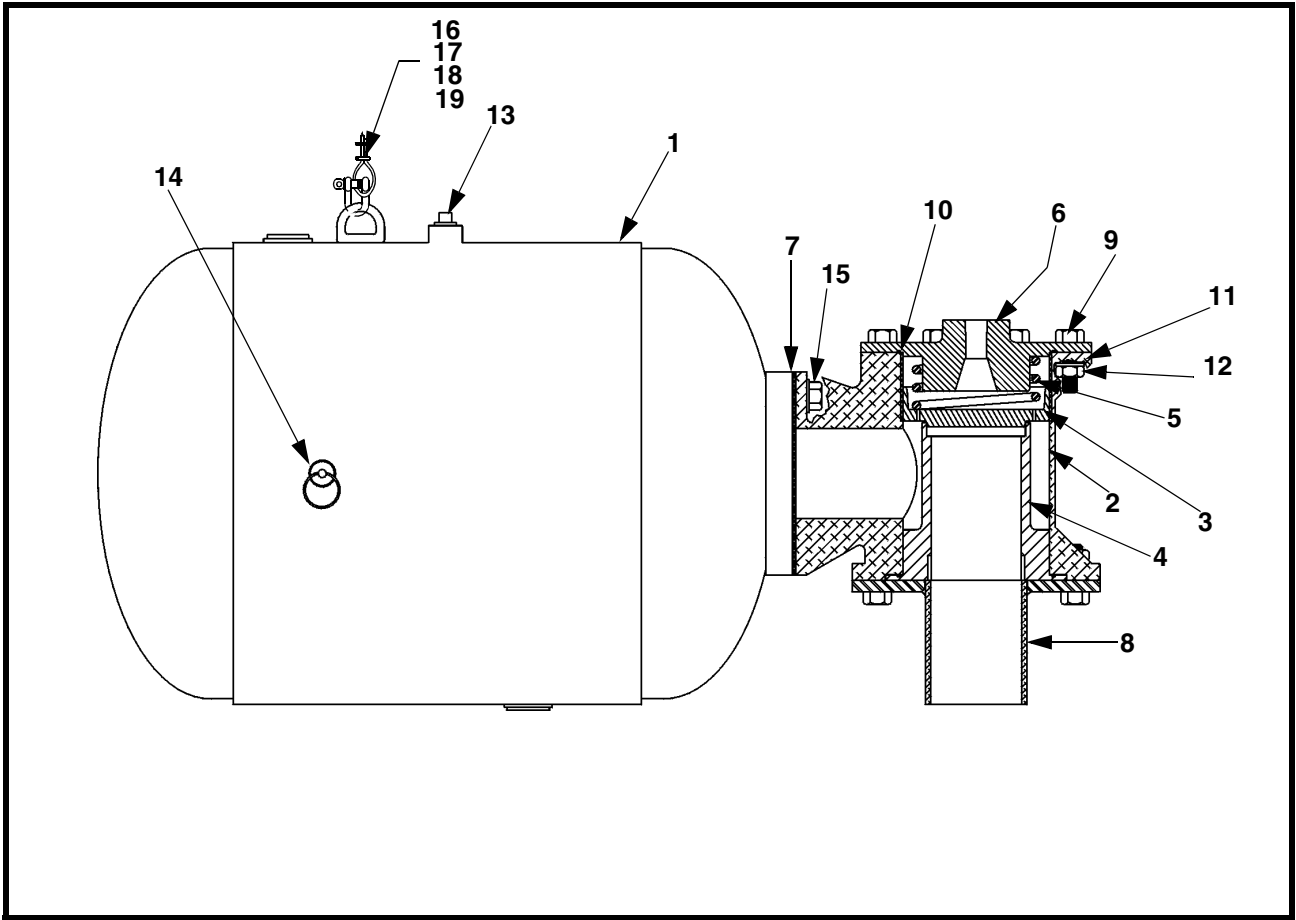

**Figure 17a. BIG BLASTER® XHV 4-in. Air Cannon Assembly, P/N 35132-XXXX**

<b>Item</b>	<b>Description</b>	<b>Part No.</b>	<b>Qty</b>
1	Tank Weldment	See Table II	1
2	Valve Body	35076	1
3	Piston with Urethane	37962	1
4	Piston Seat	35075	1
5	Compression Spring	35077	1
6	Cap	35073	1
7	Tank Gasket	35080	1
8	Discharge Flange Weldment	35081	1
9	Screw HHC 5/8 -11NC x 2 ZP	18831	16
10	O-Ring 6.75 ID Viton	35078	2
11	Washer Compression 5/8	11752	24
12	Nut Hex 5/8 - 11 NC ZP	11772	16
13	Pipe Plug 3/4 NPT	18446-01	1
14	Safety Relief Valve	21680	1
15	Screw HHC 5/8-11NC x 1-1/4 ZP	15798	8
16	Shackle 1/2	32856	1
17	Cable Clamp 1/4	32264	4
18	Wire Rope 1/4	100258	6
19	D-Ring	32265	1
20**	Label Kit	See Table II	1
*	Operator Manual	M3404	1

\*Not Shown

\*\*Refer to Appendix B.

**Figure 17b. BIG BLASTER® XHV 4-in. Air Cannon Assembly Parts List**

**Table II. BIG BLASTER® XHV 4-in. Air Cannon Part Numbers**

<b>Part No.</b>	<b>Part No. Item 1</b>	<b>Part No. Item 20</b>
35132-1228	31027-1228	34517-02E
35132-1624	33641-70	34517-02E
35132-2024	33641-100	34517-03E
35132-2030	31027-2030	34517-03E
35132-2032	33641-150	34517-03E
35132-2448	31027-2448	34517-03E
35132-3060	31027-3060	34517-03E

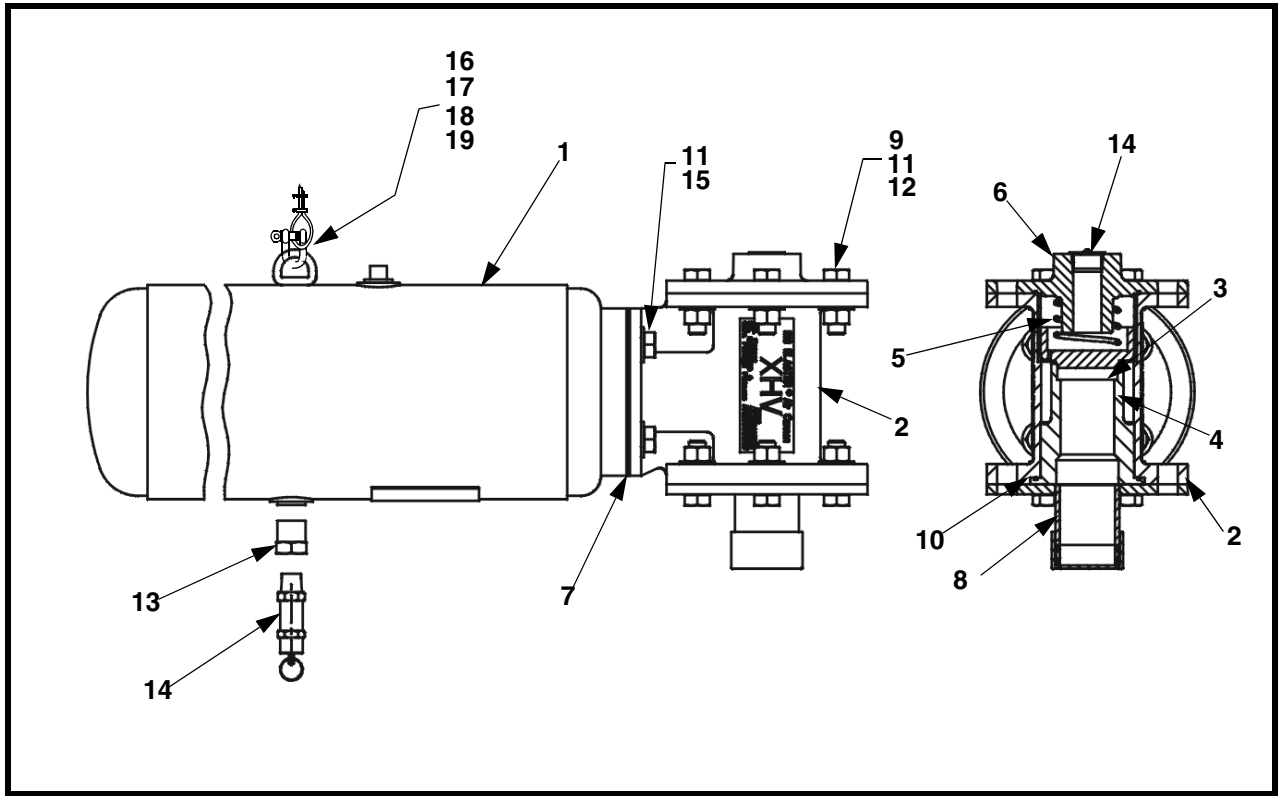

Figure 18a. BIG BLASTER® XHV 2-in. Air Cannon Assembly, P/N 35859-XXXX

<b>Item</b>	<b>Description</b>	<b>Part No.</b>	<b>Qty</b>
1	BB2 Tank Weldment	See Table	1
2	Valve Body	35853-B	1
3	Piston with Urethane	37961	1
4	Piston Seat	35861	1
5	Compression Spring	35865	1
6	Cap	35854	1
7	Tank Gasket	35872	1
8	Discharge Flange Weldment	35860	1
9	Screw HHC 5/8-11NC x 2 ZP	18831	12
10	O-ring 3-3/4 ID Viton	35863	2
11	Washer Compression 5/8	11752	16
12	Nut Hex 5/8-11 NC ZP	11772	12
13	Hex Bushing 3/4 NPT x 1/2 NPT	11875	1
14	Safety Relief Valve	21680	1
15	Screw HHC 5/8-11NX x 1-1/4 ZP	15798	4
16	Shackle 1/2	32856	1
17	Cable Clamp 1/4	32264	4
18	Wire Rope 1/4	100258	6
19	D-Ring	32265	1
**	Label Kit	34517-01E	1
*	Operator Manual	M3404	1

\*Not Shown

\*\*Refer to Appendix B.

**Figure 18b. BIG BLASTER® XHV 2-in. Air Cannon Assembly Parts List**

**Table III. BIG BLASTER® XHV 2-in. Air Cannon Tank Weldment Part Numbers**

<b>Part No.</b>	<b>Part No. Item 1</b>
35859-0812	21858
35859-0820	23128

## Notes

**Appendix A**  
**BIG BLASTER® XHV Air Cannon Specifications**

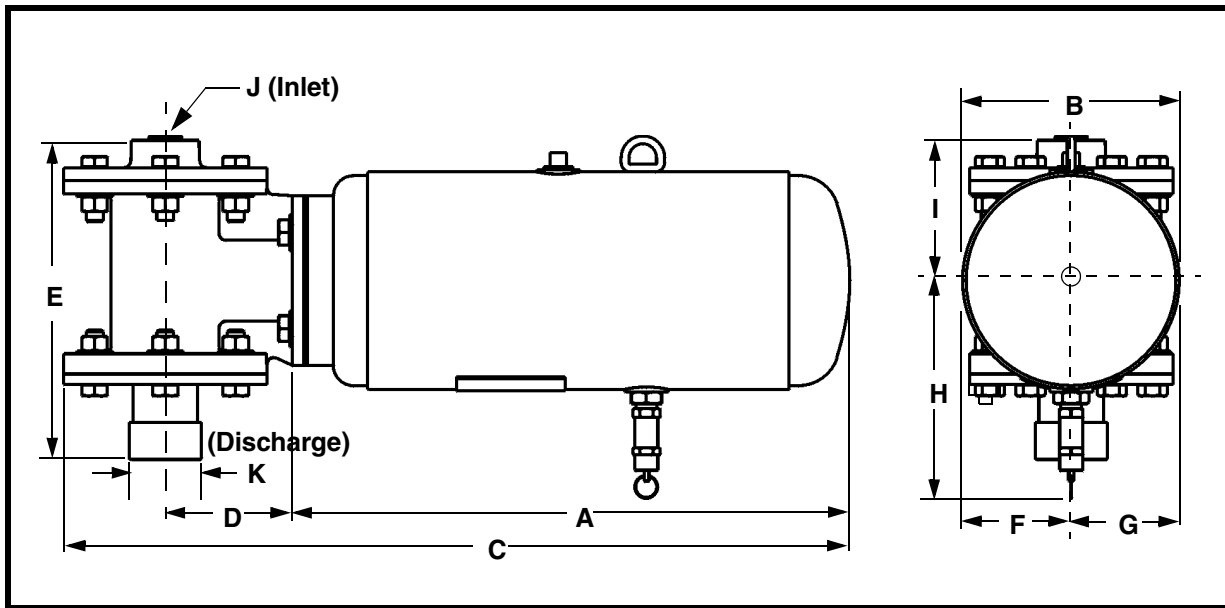

Dimensions--in. (mm)											
Model	P/N	A	B	C	D	E	F	G	H	J*	K
BB2-8-12	35859-0812	12 (305)	8 (203)	21 (533)	4.69 (119)	11.75 (298)	4 (102)	4 (102)	8.80 (224)	1	2 (51)
BB2-8-20	35859-0820	20 (508)	8 (203)	29 (737)	4.69 (119)	11.75 (298)	4 (102)	4 (102)	8.80 (224)	1	2 (51)

\* NPT - National Pipe Thread

**Figure A-1. 2-in. Air Cannon Dimensions**

**Table A-I. 2-in. Air Cannon Air Volume in Cubic Feet (Liters) Free Air**

Air Pressure psi (bar)	2-in. XHV	
	BB2-8-12	BB2-8-20
0	0.31 (9)	0.52 (15)
40 (2.8)	0.84 (24)	1.41 (40)
50 (3.4)	1.05 (30)	1.77 (50)
60 (4.1)	1.27 (36)	2.12 (60)
70 (4.8)	1.48 (42)	2.48 (70)
75 (5.2)	1.58 (45)	2.66 (75)
80 (5.5)	1.69 (48)	2.83 (80)
85 (5.9)	1.80 (51)	3.00 (85)
90 (6.2)	1.90 (54)	3.18 (90)
95 (6.5)	2.00 (57)	3.36 (95)
100 (6.9)	2.11 (60)	3.54 (100)
110 (7.6)	2.32 (66)	3.89 (110)
120 (8.3)	2.53 (72)	4.24 (120)

**Table A-II. 2-in. Air Cannon Operational Characteristics**

Model No.	Fill Time* Seconds	Discharge Time** Seconds	Noise ***		
			@80 psi (5.5 bar) dBA	@90 psi (6.2 bar) dBA	@100 psi (6.9 bar) dBA
BB2-8-12	7.38	0.09	65	67	68
BB2-8-20	12.35	0.15	70	71	71

\*Standard fill time to fully charge to supply pressure at 90 psi (6.2bar) with minimum of 50 cfm (1416 l/min) delivery.

\*\*Length of time to fully discharge tank pressure at 90 psi (6.2bar).

\*\*\*Noise measure at a distance of 4 feet (1.2 meters) for discharge into 6 tons (5442 kg) of material with bulk density of 105 lb per cubic foot (1,680 kg per cubic meter).

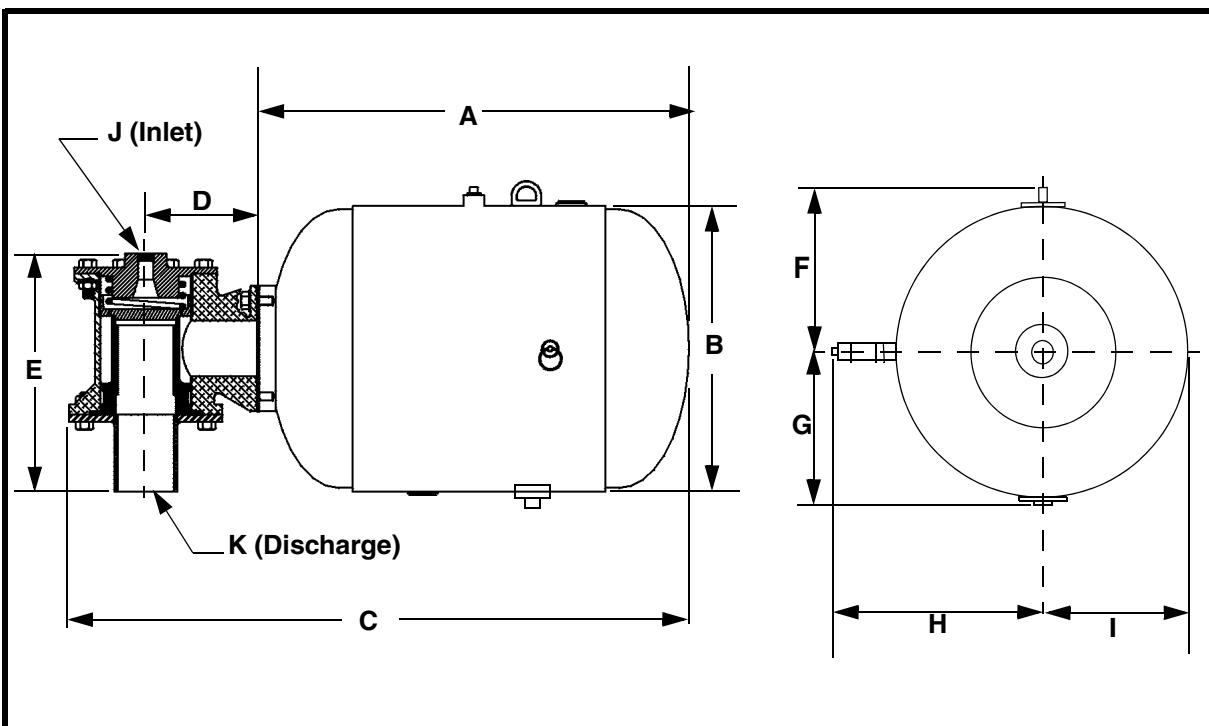

Dimensions--in. (mm)												
Model	P/N	A	B	C	D	E	F	G	H	I	J*	K
BB4-12-28	35132-1228	28 (711)	12 (305)	41.65 (1058)	8 (203)	18.5 (470)	7.5 (190)	6.5 (165)	10.6 (269)	6 (152)	1	4
BB4-20-30	35132-2030	30 (762)	20 (508)	43.65 (1109)	8 (203)	18.5 (470)	11.5 (292)	10.5 (267)	14.6 (371)	10 (254)	1	4
BB4-24-48	35132-2448	48 (1219)	24 (610)	61.65 (1566)	8 (203)	18.5 (470)	13.5 (343)	12.5 (317)	16.6 (422)	12 (305)	1	4
BB4-30-60	35132-3060	60 (1524)	30 (762)	73.65 (1871)	8 (203)	18.5 (470)	31.5 (800)	15.5 (394)	19.6 (498)	15 (381)	1	4

\* NPT - National Pipe Thread

Figure A-2. 4-in. Air Cannon Dimensions

**Table A-III. 4-in. Air Cannon Air Volume in Cubic Feet (Liters) Free Air\***

Air Pressure psi (bar)	4-in. XHV			
	BB4-12-28	BB4-20-30	BB4-24-48	BB4-30-60
0	1.70 (48)	4.48 (137)	11.51 (326)	22.49 (637)
40 (2.8)	4.63 (131)	13.17 (373)	31.32 (887)	61.20 (1733)
50 (3.4)	5.78 (164)	16.46 (466)	39.15 (1109)	76.50 (2166)
60 (4.1)	6.94 (196)	19.76 (560)	46.98 (1330)	91.80 (2600)
70 (4.8)	8.10 (229)	23.03 (652)	54.81 (1552)	107.10 (3033)
75 (5.2)	8.67 (246)	24.69 (699)	58.72 (1663)	114.75 (3250)
80 (5.5)	9.25 (262)	26.34 (746)	62.64 (1774)	122.40 (3466)
85 (5.9)	9.83 (278)	27.99 (793)	66.55 (1885)	130.00 (3683)
90 (6.2)	10.41 (295)	29.63 (839)	70.47 (1996)	137.70 (3900)
95 (6.5)	11.00 (311)	31.28 (886)	74.38 (2107)	145.34 (4116)
100 (6.9)	11.57 (328)	32.93 (933)	78.30 (2217)	153.00 (4333)
110 (7.6)	12.72 (360)	36.22 (1026)	86.13 (2439)	168.30 (4766)
120 (8.3)	13.88 (393)	39.51 (1119)	93.96 (2661)	183.60 (5200)

**Table A-IV. 4-in. Air Cannon Operational Characteristics**

Model No.	Fill Time* Seconds	Discharge Time** Seconds	Noise ***		
			@80 psi (5.5 bar) dBA	@90 psi (6.2 bar) dBA	@100 psi (6.9 bar) dBA
BB4-12-28	40.23	0.12	75	80	80
BB4-20 30	114.44	0.31	80	82	82
BB4-24-48	272.00	0.79	82	83	84
BB4-30-60	531.57	1.54	83	84	86

\*Standard fill time to fully charge to supply pressure at 90 psi (6.2bar) with minimum of 50 cfm (1416 l/min) delivery.

\*\*Length of time to fully discharge tank pressure at 90 psi (6.2bar).

\*\*\*Noise measure at a distance of 4 feet (1.2 meters) for discharge into 6 tons (5442 kg) of material with bulk density of 105 lb per cubic foot (1,680 kg per cubic meter).

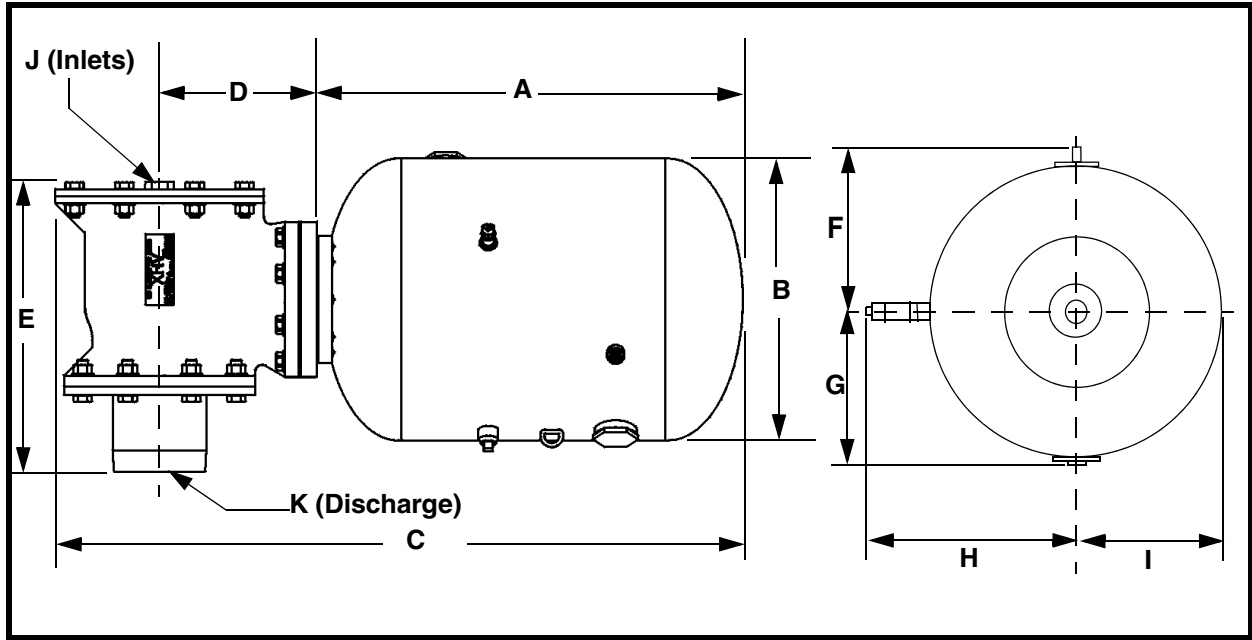

Dimensions--in. (mm)												
Model	P/N	A	B	C	D	E	F	G	H	I	J*	K
BB6-20-30	36260-2030	30 (762)	20.00 (508)	48.00 (1219)	8.00 (203)	20.5 (521)	10.75 (273)	10.25 (267)	12.25 (317)	10.50 (254)	1	6
BB6-24-48	36260-2448	48 (1219)	24.00 (610)	66.00 (1676)	8.00 (203)	20.5 (521)	12.75 (324)	12.25 (317)	14.25 (422)	12.50 (305)	1	6
BB6-30-60	36260-3060	60 (1524)	30.00 (762)	78.00 (1981)	8.00 (203)	20.5 (521)	15.75 (400)	15.75 (394)	17.25 (498)	15.50 (381)	1	6

\* NPT - National Pipe Thread

**Figure A-3. 6-in. Air Cannon Dimensions**

**Table A-V. 6-in. Air Cannon Air Volume in Cubic Feet (Liters) Free Air**

Air Pressure psi (bar)	6-in. XHV		
	BB6-20-30	BB6-24-48	BB6-30-60
0	4.48 (137)	11.51 (326)	22.49 (637)
40 (2.8)	13.17 (373)	31.32 (887)	61.20 (1733)
50 (3.4)	16.46 (466)	39.15 (1109)	76.50 (2166)
60 (4.1)	19.76 (560)	46.98 (1330)	91.80 (2600)
70 (4.8)	23.03 (652)	54.81 (1552)	107.10 (3033)
75 (5.2)	24.69 (699)	58.72 (1663)	114.75 (3250)
80 (5.5)	26.34 (746)	62.64 (1774)	122.40 (3466)
85 (5.9)	27.99 (793)	66.55 (1885)	130.00 (3683)
90 (6.2)	29.63 (839)	70.47 (1996)	137.70 (3900)
95 (6.5)	31.28 (886)	74.38 (2107)	145.34 (4116)
100 (6.9)	32.93 (933)	78.30 (2217)	153.00 (4333)
110 (7.6)	36.22 (1026)	86.13 (2439)	168.30 (4766)
120 (8.3)	39.51 (1119)	93.96 (2661)	183.60 (5200)

**Table A-VI. 6-in. XHV Air Cannon Noise Levels**

Model No.	Fill Time* Seconds	Discharge Time** Seconds	Noise ***		
			@80 psi (5.5 bar) dBA	@90 psi (6.2 bar) dBA	@100 psi (6.9 bar) dBA
BB6-20-30	114.44	0.14	90	93	94
BB6-24-48	272.00	0.36	92	94	95
BB6-30-60	531.57	0.69	93	95	96

\*Standard fill time to fully charge to supply pressure at 90 psi (6.2bar) with minimum of 50 cfm (1416 l/min) delivery.

\*\*Length of time to fully discharge tank pressure at 90 psi (6.2bar).

\*\*\*Noise measure at a distance of 4 feet (1.2 meters) for discharge into 6 tons (5442 kg) of material with bulk density of 105 lb per cubic foot (1,680 kg per cubic meter).

## Notes

**Appendix B**  
**BIG BLASTER® XHV Air Cannon Labels**



Air Cannon Warning Label, P/N 33439

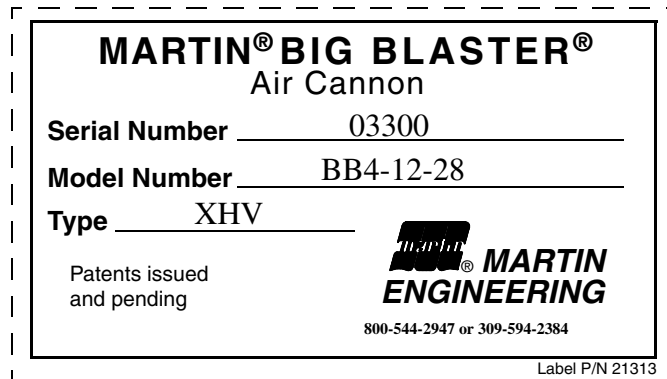

BIG BLASTER® Serial/Model Number Label, P/N 21313

**! ADVERTENCIA**

**! WARNING**

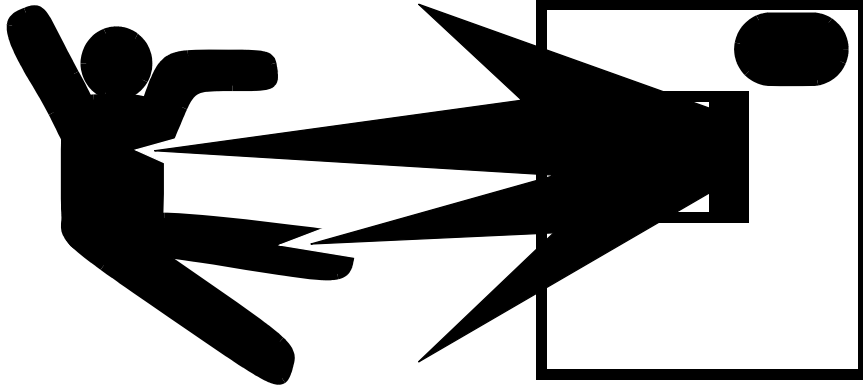

**Air cannon(s) are mounted on this structure.**

**DO NOT OPEN this door until you:**

- 1. Lock out/tag out all power.**
- 2. Purge line pressure.**
- 3. Vent air from all cannons.**

**Opening this door while cannons are operational can kill you.**

**Detonador(es) neumaticos son montados en esta estructura.**

**NO ABRA la puerta sin haber:**

- 1. Bloquee/rotule todas fuentes de energía.**
- 2. Purga la presión de línea.**
- 3. Ventile el aire de los detonadores.**

**Abrir esta puerta mientras los cañones están operando puede ser mortal!**

Label P/N 31913

**Air Blast Warning Label, P/N 31913**

○

<b>⚠ ADVERTENCIA</b>
<b>⚠ WARNING</b>

<b>Shutting off the lockout ball valve will cause the air cannons on this structure to fire immediately.</b> <b>DO NOT shut off the valve until you make sure no one is in the structure or near its discharge.</b> <b>Flying debris from the cannons' blast can kill you!</b>
<b>Cerrar la válvula de cierre estilo bola causará que los cañones de aire en la tolva disparen inmediatamente. Antes de cerrar la válvula, asegúrese que nadie este dentro de la tolva o cerca de la descarga de la tolva. Escombros volantes pueden causar heridas serias o muerte.</b>

Label P/N 35146

Lockout Valve Warning Tag, P/N 35146

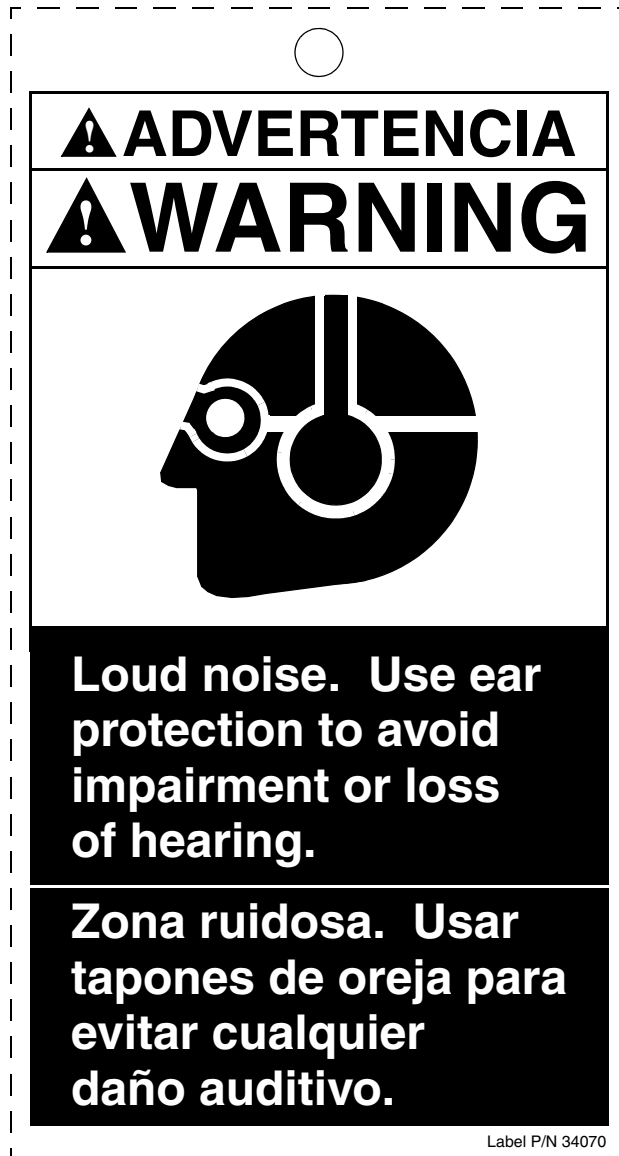

**Loud Noise Warning Tag, P/N 34070**

## Notes

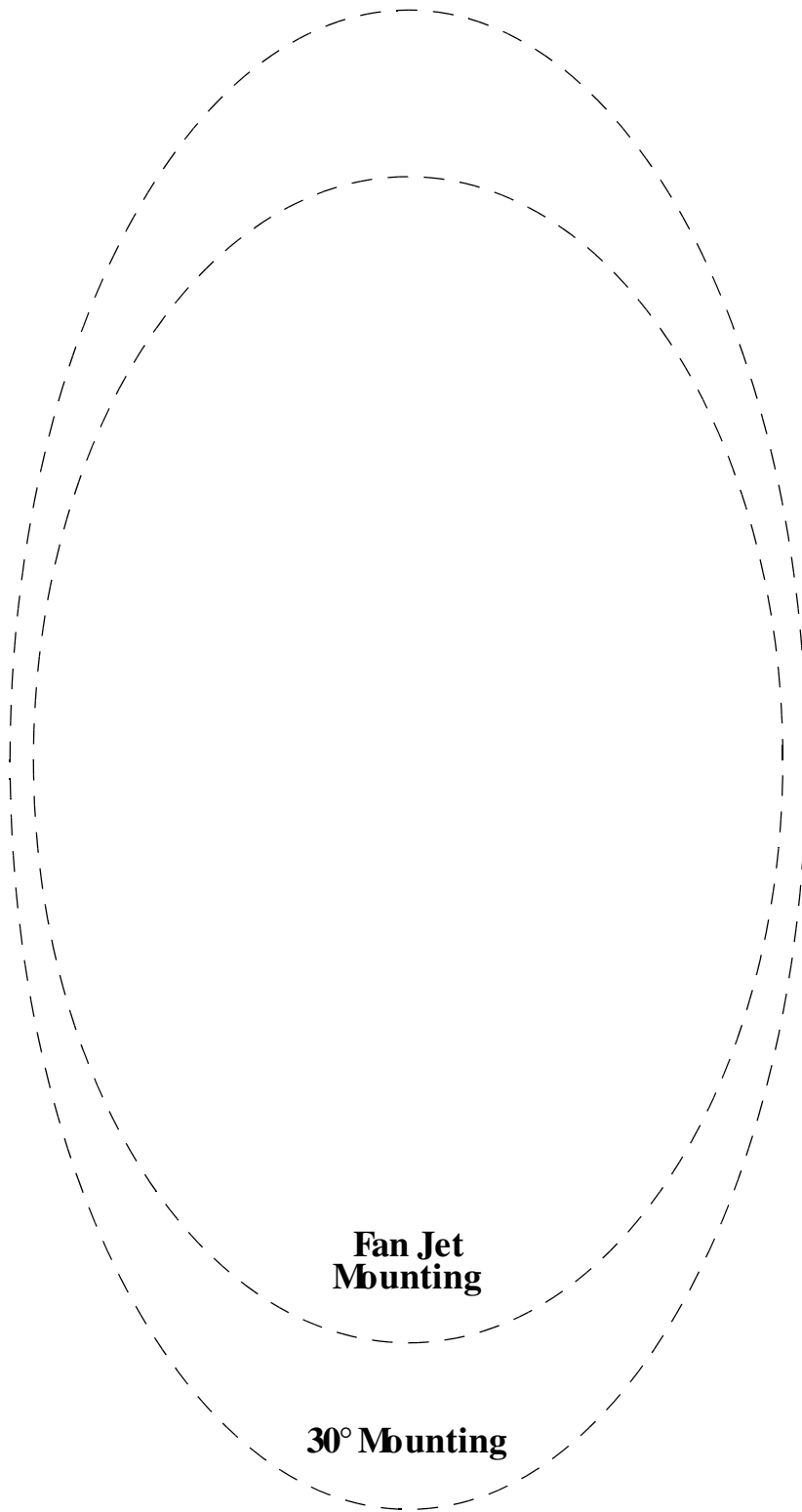

**Mount 30° mounting plates vertically.  
Mount fan jet mounting plates either vertically or horizontally.  
Contact Martin Engineering for more information.**



*Any product, process, or technology described here may be the subject of intellectual property rights reserved by Martin Engineering Company. Trademarks or service marks designated with the ® symbol are registered with the U.S. Patent and Trademark Office and may be proprietary in one or more countries or regions. Other trademarks and service marks belonging to Martin Engineering Company in the United States and/or other countries or regions may be designated with the “TM” and “SM” symbols. Brands, trademarks, and names of other parties, who may or may not be affiliated with, connected to, or endorsed by Martin Engineering Company, are identified wherever possible. Additional information regarding Martin Engineering Company’s intellectual property can be obtained at [www.martin-eng.com/trademarks](http://www.martin-eng.com/trademarks).*

# ***Problem Solved™***



**Martin Engineering USA**

One Martin Place  
Neponset, IL 61345-9766 USA  
800 544 2947 or 309 852 2384  
Fax 800 814 1553  
[www.martin-eng.com](http://www.martin-eng.com)

Subject to change without prior notice.

Quality Management System Certified by DNV - ISO 9001

**QUALITY MANAGEMENT SYSTEM  
CERTIFIED BY DNV**

**==== ISO 9001:2008 ====**